

# Fourth International Workshop on Smart Sensors in Livestock Monitoring

Marcella Guarino, [marcella.guarino@unimi.it](mailto:marcella.guarino@unimi.it), Department of Veterinary Science and Technology for Food Safety, University of Milan, Via Celoria 10, 20133 Milan, Italy  
Daniel Berckmans, [daniel.berckmans@biw.kuleuven.be](mailto:daniel.berckmans@biw.kuleuven.be), Department of Biosystems, Katholieke Universiteit Leuven, Kasteelpark Arenberg 30, 3001 Leuven, Belgium



# smart 2006



UNIVERSITÀ  
DEGLI STUDI  
DI MILANO

organised by

KATHOLIEKE UNIVERSITEIT  
LEUVEN

22-23 September 2006, Gargnano, Italy



Welcome,

The *on-line monitoring* of animals and their behaviour becomes more important to realise a better animal welfare and more animal health. The fact that animals can be monitored *continuously* during 24 hours a day and 7 days a week will be a big advantage. A more *objective quantification* of animal responses and animal behaviour by modern technology will be another big step ahead to reach the goals as set by EU. Moreover we hope to develop these techniques to the level that the continuous on-line animal monitoring works in a *fully automatic way*.

It is clear that the challenges that we have to overcome are enormous but the research that is required and that brings all of us together in the Smart Sensors Workshops for livestock monitoring is very exciting both from scientific and technological viewpoint.

To realise this goal we have to bring together animal scientists, ethologists, physiologists, veterinarians to meet with engineers, signal analyzers, physicists, modellers and other sensor developers. This clearly is a multidisciplinary field of research.

A lot of knowledge has to be developed and the research in this field needs of course funding. To find this necessary funding we all have to *write good research proposals* since this is a task we have to realise. We also need to convince our policy makers that this field of research is very important since the health and welfare of our livestock is a crucial link in a healthy food chain. It is a pleasure to notice that EU has interest in what we are doing and we thank them for their interest.

To bring these developments to reality and to implement this knowledge into the EU livestock production system, we need a strong collaboration with industrial partners. This 4<sup>th</sup> SMART2006 is possible because our industrial sponsors are interested to realise with us the technological challenges in Precision Livestock Farming. In the name of all of you present here I wish to express my thanks to our sponsors since without them we wouldn't be here today.

I wish all of you a very good workshop.

Dr. Marcella Guarino  
Workshop Chair  
Università degli Studi di Milano  
Italy

## **TABLE OF CONTENTS**

TABLE OF CONTENTS .....	2
ORGANISATION .....	3
LOCATION & DATE .....	3
WORKSHOP PROGRAMME .....	4
ABSTRACTS .....	7
LIST OF AUTHORS .....	61

## **ORGANISATION**

The Fourth Workshop on Smart Technologies in Livestock Monitoring is organised by:

Practical organization:

Dipartimento di Scienze e Tecnologie Veterinarie per la  
Sicurezza Alimentare (VSA)  
Università degli Studi di Milano  
Via Celoria 10 Milano.  
Italy

Tel. 0039 02 503 17909  
Fax. 0039 02 503 17909  
E-mail: marcella.guarino@unimi.it

Scientific organization:

Measure, Monitor and Manage Bioresponses (M3-BIORES),  
Katholieke Universiteit Leuven  
Kasteelpark Arenberg 30  
3001-Heverlee  
Belgium

Tel: 0032 16 32 17 26  
Fax: 0032 16 32 14 80

### **SCIENTIFIC COMMITTEE**

- Dr. Marcella Guarino, Workshop Chair (Italy)
- Prof. Daniel Berckmans (Belgium)
- Dr. Ephraim Maltz (Israel)
- Prof. Jos Metz (The Netherlands)
- Prof. Christopher Wathes (UK)
- Prof. Hongwei Xin (USA)

## **LOCATION & DATE**

The workshop is held on 22-23 September 2006 in Gargnano, Brescia, in the beautiful Palazzo Feltrinelli.





**Session 5: POSTER SESSION ON COW AND CATTLE page 27 Chair: Hongwei Xin**

**16:20 – 16:25 Poster 1**

Application of thermal imaging for cattle management

*Brehme U., Ahlers D., Beuche H., Hasseler W. and Stollberg U..*

**16:30 – 16:35 Poster 2**

Monitoring pasture time in strips of new grass using wireless sensor networks

*Nadimi E. S., Oudshoorn F. W. and Bak T.*

**16:35 – 16:40 Poster 3**

Model-based calving monitor using real time image analysis

*Cangar O., Leroy T., Guarino M., Fallon R., Lenehan J. and Berckmans D.*

**Session 6: VARIOUS TOPICS page 33 chair: Ilan Halachmi**

**16:40 – 17:05 Lecture 11**

A novel test chamber for laboratory mice

*Green A.R., Wathes C.M., Demmers T.G.M., MacArthur-Clark J. and Xin H.*

**17:05 – 17:30 Lecture 12**

Monitoring of swarming sounds in bee hives for prevention of honey loss

*Ferrari S., Silva M., Guarino M. and Berckmans D.*

**17:30 – 17:55 Lecture 13**

A new experimental facility for animal welfare and precision livestock farming research

*Demmers T.G.M., Lowe J.C. and Wathes C.M.*

**Session 7: POSTER SESSION ON VARIOUS TOPICS page 37 Chair: Özlem Cangar**

**18:05 – 18:10 Poster 4**

Computer vision system to evaluate piglets welfare.

*Naas I.A., Moura D.J., Silva W.T., Mendes A.S. and Lima K.A.O.*

**18:10 – 18:15 Poster 5**

Leia-low-end image analysis to continuously monitor growth and body conformation of fattening pigs

*Appel C., Jungbluth T. and Hartung E.*

**18:15 – 18:20 Poster 6**

Using fish responses to environmental conditions

*Halachmi I.*

**18:20 – 18:25 Poster 7**

Controlling heart rate of horses as a basis for training improvement

*Aerts J.-M., Gebruers F., Van Camp E. and Berckmans D.*

**19:30 Dinner**

**Saturday, September 23rd**

**Session 8: EGGS AND INCUBATORS page 45 Chair: Nick French**

**08:30 – 08:55 Lecture 14**

Overview of incubation parameters  
*French N.*

**08:55 – 09:20 Lecture 15**

Nitric oxide emitted from incubated eggs: Can it be used to indicate embryonic stress?  
*Ar A.*

**09:20 – 09:45 Lecture 16**

Development of thermoregulation in poultry embryos and its influence by incubation temperature  
*Tzschentke B.*

**09:45 – 10:10 Coffee break**

**Session 9: Poster session on eggs and broilers page 49 Chair: Daniel Berckmans**

**10:10 – 10:15 Poster 8**

Non-destructive on-line measurement of albumen pH of chicken embryo's as a response on CO<sub>2</sub> concentration  
*Van Brecht A. and Berckmans D.*

**10:15 – 10:20 Poster 9**

Effects of different target trajectories on the broiler performance in growth control  
*Cangar Ö., Aerts J.-M., Vranken E. and Berckmans D.*

**10:20 – 10:25 Poster 10**

Algorithm for measurement of the dairy cow's body parameters by using image processing  
*Hyeon T. Kim, Han J. Ko, Dae W. Lee, T. Nishizu*

**Session 10: REAL-TIME ALGORITHMS IN THE FIELD Chair: Erik Vranken**

**10:25 – 10:50 Lecture 17**

Building blocks for an embedded architecture  
*Van de Vondel B.*

**10:50 – 11:15 Lecture 18**

Software-based design for embedded applications  
*Mulliner J.*

**11:15 – 11:40 Lecture 19**

Model-based design with simulink  
*Pacchiodo R.*

**Session 11: COW page 55 chair: Ephraim Maltz**

**11:40 – 12:05 Lecture 20**

Utilisation of GPS herd activity and welfare kit (GPS hawk) to determine optimum sampling parameters for intensively monitoring beef cattle  
*Davis J.D., Xin H., Harmon J.D. and Russell J.R.*

**12:05 – 12:30 Lecture 21**

An automated method of simple behaviour classification as a tool for management improvement in extensive systems  
*Umstatter C., Waterhouse A. and Holland J.*

**12:30 – 11:55 Lecture 22**

Measurement of animal data and their importance for herd management on dairy cow farms  
*Brehme U. and Brunsch R.*

**12:55 – 13:20 Conclusions of SMART2006 Workshop Chair: Marcella Guarino**

**13:20 – 14:20 Lunch**

## **MONITORING RUMEN PH BY WIRELESS TELEMETRY IN DAIRY COWS**

Toby Mottram, John Lowe, Michael McGowan, Nancy Phillips, Dennis Poppi

*Corresponding author: Toby Mottram, Well Cow Ltd., Roslin Bioscience Centre, Scotland,  
Toby.mottram@wellcow.co.uk*

---

Ruminant animals convert forage containing cellulose by bacterial fermentation into nutrients. The health of the bacterial culture in the rumen is essential for the health and productivity of the animal. Over a number of years fistulated animals have been used to study the rumen and its bacterial population. It has been shown that techniques to maintain the pH of the rumen between 7 and 5.5 pH are essential for the health of the dairy cow. The rumen pH has been recorded by using sensors suspended in the rumen at intervals or exceptionally with data recorders. However, fistulation of an animal requires surgery and is only suitable for a few research animals. This paper describes the use of a telemetric bolus to measure and record pH in the rumen continuously. When interrogated by wireless the bolus transmitted the recorded data to an operator standing beside the cow with a receiving station. Boluses were placed in fistulated animals so that a comparison could be made with a laboratory instrument. Data are presented that show a close correlation between the calibrated laboratory instrument and the bolus at time intervals when the instrument was inserted. It can be assumed that the bolus accurately records the temporal variation in rumen pH. Data are presented to show the diurnal change in rumen pH over extended periods. Methods of increasing the lifetime and accuracy of the bolus are discussed.

## **AUTOMATIC BLOOD SAMPLING IN DAIRY COWS**

\*Fonss A. and Munksgaard L.

*Danish Institute of Agricultural Sciences, Research Centre Foulum, Dept. of Animal Health, Welfare and Nutrition, Blichers Allé 20, P.O. BOX 50, DK-8830 Tjele, Denmark*

*\*e-mail corresponding author: anders.fonss@agrsci.dk*

---

Loose housing systems for dairy cows are becoming more common and this raises new questions within the area of animal health and welfare. Some of these questions can be addressed by studying variation in blood parameters like for instance glucocorticoids. However the traditional manual blood sampling procedure can by itself affect the responses of the animal. Therefore we have developed a device for wireless, automated collection of multiple blood samples with variable intervals between sampling. The device is placed on the back of the animal and allows the animal to be kept in all types of environments either alone or in social groups. The animal can move freely, no restraint and no handling of the animal during blood sampling is necessary.

Two experiments were conducted to study how the blood sampling procedure affected the cortisol responses in dairy cows.

In one experiment automatic samples were collected from 6 cows kept in tie-stalls with 3 minute samplings interval for 39 minutes. At time 12, 24, 36 and 39 a manual sample was taken by vein puncture. None of the cows showed a consistent increased cortisol response to automatic sampling, while two cows showed increased cortisol concentration after vein puncture.

In a second experiment 12 cows kept in a loose housing system were subjected to automatic blood sampling. In the morning during a period of 1.5 hours, 14 blood samples were taken with varying time intervals from each cow. In the afternoon 14 samples were taken over a 2.5 hours period. Cortisol concentrations in the blood samples suggest that the cows were not affected by the blood sampling procedure.

On some occasions during the experiments it was not possible to acquire a sample. For the manual vein puncture, 3 samples out of 24 (12.5%) were not successfully taken within the time limits of 2 minutes. As for the automatic blood sampling, the catheter occasionally got twisted and blocked by the movement of the cow's head, this occurred in 8 out of 84 samples (9.5%). In four of the manual samples, considerable haemolysis had occurred during the sampling procedure. No haemolysis was observed in the automatic blood samples.

Automated blood sampling offers the opportunity to collect series of samples without disturbing the animal. Data suggests that even in a tie barn automatic blood sampling is a better alternative to manual blood sampling.

## ON-LINE MEASUREMENT OF MILK CONTENTS IN PRECISION DAIRY FARMING

\*Halachmi I., Schmilovitch Z., Maltz E. and Antler A.

*Institute of Agricultural Engineering, Agricultural Research Organization, the Volcani Center, P.O. Box 6, Bet Dagan 50250, Israel.*

*\*e-mail corresponding author: halachmi@volcani.agri.gov.il*

---

### INTRODUCTION

The voluntary feed intake or DMI of the dairy cow is an important variable in cow management as it facilitates the nutritional formulation of rations. In conjunction with milk yield it can be used to estimate the economic value of an individual cow at any given stage of lactation, and hence to improve the economic decisions of the whole operation. Where concentrates are allocated individually, as in robot-milking dairies, this variable becomes crucial for nutritional management reasons. In conventional dairies where the cows are kept in groups, DMI can be measured only by weighing mixer wagons for a group of cows (Halachmi *et al.*, 1998). Individual DMI can be evaluated by modelling, based on measurable variables that are known to affect it. In a previous study Halachmi *et al.* (2004) developed a model that predicts the DMI of the individual cow. However the model lacks the milk contents inputs since at that stage it was measurable only once each 4 to 6 weeks by the national milk recording scheme. In the current study, a milk contents sensor was developed in order to provide the missing data that will improve the DMI model accuracy.

### OBJECTIVES

The objectives of this study were, to evaluate the contribution of on-line milk composition data of individual cows provided by a new sensor to the accuracy of DMI modelling for individual cows.

### METHODS

A sensor for milk fat, protein, and lactose (so called milk contents) is under development at the Volcani centre in cooperation with S.A.E. Afikim® (Kibbutz Afikim, Israel). It is installed in the milking parlour and provides on-line milk composition data for each milking session for each cow. Out of the whole herd, 42 cows are kept in a fully roofed shade in which feed intake of each cow can be measured individually (Halachmi *et al.*, 1998). The cows were milked 3 times daily and food was offered once daily.

The feed intake, milk yield milk composition and body weight data were collected daily and the predicted DMI intake was calculated (Halachmi *et al.*, 2004) for each cow by two methods. Firstly, milk composition was incorporated as the same value as if measured periodically, and secondly when milk composition provided daily by the new sensor were incorporated daily into the formula.

### RESULTS AND DISCUSSION

The data in Figure 1 shows that there was rather large natural fat flocculation during the observed 3 weeks period. The average STD was 0.2623% and average spread was 0.9332% where spread is max-min of one single cow during the 3 weeks period. Consequently, the current situation of milk recording only once every 4 to 6 weeks might not be sufficient for precision farming and a daily used on-line sensor for milk contents is required.

It can be seen (Figure 2) that a 26% error results with 5 kg DM change in feed intake per day. The 26% value is one single standard deviation. For instance if 4% fat turns into 5% fat, the DMI prediction might be 35kg instead of 30 kg per day. It is a well known fact that milk composition of any cow fluctuates daily as well as between milkings. It seems that the new sensor provides information, so far absent, that improves DMI modelling.

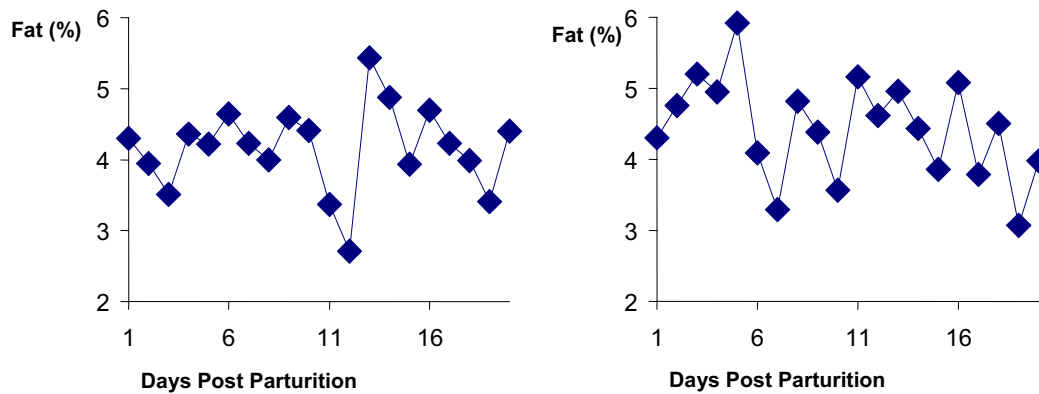

**Figure 1.** Natural daily fluctuation of fat milk percentages of two typical cows. The data was sampled every day and was sent to the national milk recording laboratory. The data was not measured by the new sensor

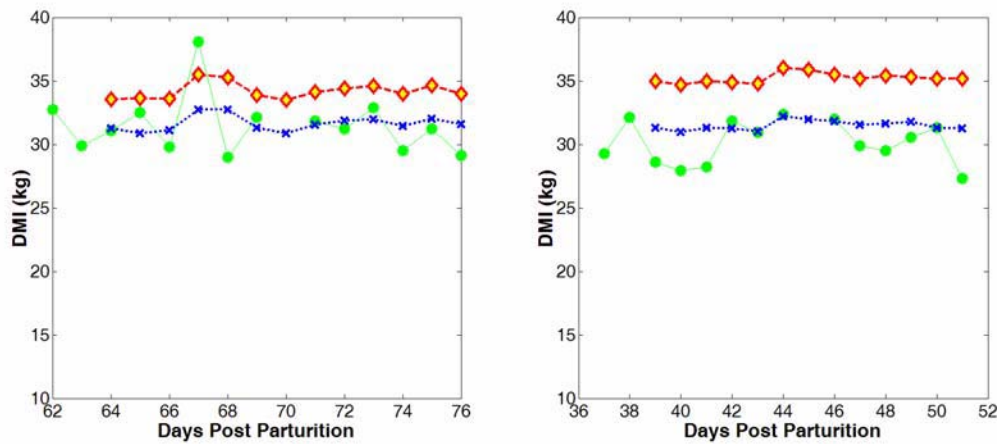

**Figure 2.** Modelling the individual cow dry matter intake; observed (o), on-line daily based prediction (x) vs. single milk recording based prediction (◇).

## CONCLUSIONS

On-line measurement of milk contents was developed (hardware) and applied (model + software) for accessing the feed intake of a dairy cow kept in a group. The onus now is on the industry to use the sensor and the model. More work is needed in order to implement successfully this new technology in the dairy industry.

## REFERENCES

1. Halachmi, I., Edan Y., Maltz, E., Peiper, U. M., Brukental, I. and Moalem, U. 1998. A real-time control system for individual dairy cow food intake. *Computers and Electronics in Agriculture* 20: 131-144
2. Halachmi, I., Edan, Y., Moallem, U. and Maltz, E. 2004. Predicting feed intake of the individual dairy cow. *Journal of Dairy Science*, 87(7):2254-2267

## REAL-TIME MONITORING OF THE BODY TEMPERATURE WITH A RUMEN BOLUS

<sup>1</sup>Ipema A., <sup>1</sup>Goense D., <sup>1</sup>Hogewerf P., <sup>1</sup>Houwers W. and <sup>1</sup>Roest van H.

<sup>1</sup>Animal Sciences Group of Wageningen UR, P.O. Box 65, 8200 AB Lelystad, The Netherlands  
\*e-mail corresponding author: e-mail: bert.ipema@wur.nl

---

### INTRODUCTION

Monitoring of animals is mainly done for operational control of farm processes. It is expected that these control activities will gain importance because of the public concern about food safety and animal health and welfare. This also means that there is a growing need for collecting more and more accurate information from individual animals in a herd. On the other hand the average herd size is increasing so that the herdsman has less time available for an individual cow. Sensors can be helpful to collect individual cow information. Several research groups and companies are working to this end on the development of wireless sensor systems. Basic parts of these systems are motes. A mote is a unit with a sensor(s), processor and means of communication. In this report our experiences with a temperature mote build in a rumen bolus are described.

### OBJECTIVES

To study the feasibility of measuring body temperature with a wireless temperature sensor mote in a rumen bolus.

### METHODS AND RESULTS

The test set up consisted of a PC, a base station, an antenna and two motes applied to a cow (figure 1).

The PC had a Pentium 3 processor of 800 MHz. Communication with the base station took place over an RS232 port. The base station (Mib510) was powered by 5V and was permanently connected with a Mica2 mote [1], which served as the interface between the Mib510 and the motes applied to the cow. These motes had 5V battery for the energy supply and a CC1000 radio chip and a small antenna for FM radio communication at 433 MHz. The chip, antenna, battery and temperature sensor were built into a small pipe with a diameter of 3.5 cm and a length of 10.6 cm and weighing 106 g. Because it was expected that the signal strength of the radio in the rumen mote was too weak to reach the antenna of the base station an additional mote was attached to the left front leg of the cow. This mote only receives the signal from the rumen mote and relayed the information to the base station. Eight days before calving the mote was applied into the rumen of a fistulated dry cow. One day after calving the measurements ended. The transmitting frequency of the motes was set at approximately one measurement per minute. Research about the technical aspects mainly focussed on the reliability of the direct radio transmission between the rumen mote and the base station. All measurements were buffered by an implemented internal logging in the mote. After the bolus was removed from the rumen this buffer was emptied by the base station.

Table 1 gives for days 7 till 5 before calving a comparison between the direct transmitted measurements and the measurements received afterwards from the buffer. Less than 50% of the measured temperatures that were stored in the mote buffer were directly (real-time) received by the base station. In day 5 before calving this number was lowest. Also in this day the largest time gap between two consecutive data transmissions was recorded; this period without data transmission lasted 121 min. Data transmission often failed when the cow was lying on her left side. Despite the lower number, the mean, maximum, minimum and standard error of the temperatures did not show large differences.

Sensor measurements and transmission of this information cost energy. In this research the frequency was set at one measurement per minute. This gave a good possibility to study the rumen temperature profile during the day of calving (figure 2). It is striking that the temperature during the largest part of the day is lower than the mean temperatures on the days before calving (table 3). This was also noticed in earlier research [2]. During the day of calving the temperature decreased further with a big decrease during and immediately after birth.

## CONCLUSIONS

Direct communication of the mote in the rumen bolus with the base station often fails; this can be solved by buffering data in the mote.

The frequency of sensor measurements and data transmission should be tuned to the required aim. For example during the period when the birth of the calf is expected, the frequency should be higher for timely attention. Too high frequencies are not preferred because of energy efficiency.

**Table 1. Comparison between data form and direct received data.**

Days before calving	<----- Data from buffer ----->				<----- Direct received data ----->						
	Number	Temperature (°C)			Number	Temperature (°C)			Gap <sup>1</sup> (min)		
	n	mea	Se	max	min	n	Mea	Se	Max	Min	
7	1477	40.1	0.53	41.6	38.4	632	40.0	0.50	41.6	38.4	61
6	1475	40.1	0.57	40.8	36.5	726	39.9	0.70	40.7	36.5	44
5	1472	40.0	0.72	41.1	36.7	477	39.9	0.57	41.1	36.7	121

Gap<sup>1</sup>: means largest time gap in minutes between two consecutive received data transmissions

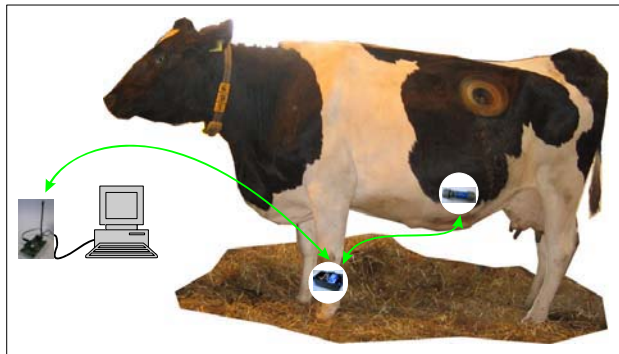

**Figure 1.** Test setup for wireless rumen temperature measurements

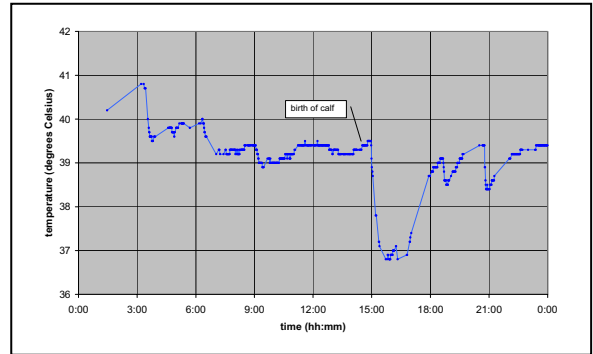

**Figure 2.** Rumen temperature during day of calving

## References

1. Crossbow Technology Inc., "Wireless Sensor Networks, TinyOS, Berkley Motes from Crossbow", [http://www.xbow.com/Products/Wireless\\_Sensor\\_Networks.htm](http://www.xbow.com/Products/Wireless_Sensor_Networks.htm).
2. Metz, J., F. Wiersma, W. Rossing and V. van den Berg, 1987. Preliminary research with an implantable telemetric system for measuring the body temperature of dairy cows. Institute of Agricultural Engineering. Wageningen, The Netherlands. Research Report 87-2, 32 pp.

## EYENAMIC: REAL-TIME MEASUREMENT OF PIG ACTIVITY IN PRACTICAL CONDITIONS

Leroy T.<sup>1</sup>, Mentasti T.<sup>2</sup>, Costa A.<sup>2</sup>, Guarino M.<sup>2</sup>, Aerts J.-M<sup>1</sup>., Berckmans D.<sup>1</sup>

<sup>1</sup>*Division Measure, Model & Manage Bioresponses, Katholieke Universiteit Leuven, Kasteelpark Arenberg 30, B-3001 Leuven, Belgium, e-mail: daniel.berckmans@biw.kuleuven.be.*

<sup>2</sup>*Department of Veterinary and Technological Sciences for Food safety, Faculty of Veterinary Medicine, via Celoria, 10, 20133 Milan, Italy.*

---

One way to tackle the problem of dust concentrations in pig housing is to avoid or suppress the peak concentrations that are caused by agile movements of the pigs. However, to control the activity of the pigs, reliable sensors to measure their activity level continuously in an on-line way are needed.

The purpose of the reported research was to develop a method for measuring the activity level of pigs in a pen in real time so that in a next step the relation between the measured activity level and the dust concentration in the pen can be identified.

For the experiments, two adjacent pig pens were used; each measuring 6.9m x 2.6m in size and each housing 15 pigs. The equipment used for activity measurement consisted of an infrared-sensitive CCD camera (Sanyo VCB-3572IRP) that was mounted to the roof, 4 m above the floor of the pen and connected to a PC with built-in frame grabber (Data Translations DT-3210) using a coaxial cable. The camera was in a protective housing to shield it from dust and moisture. The lens was pointed downwards to get a top view of the pen. Images were captured with a resolution of 768x586 and a 1 fps frame rate.

Prior to the experiments, the camera was calibrated by outlining a piece of the pen wall with known dimensions in an image taken from the mounted camera. This way, the relationship between the physical unit (m) of the pen and the image pixel could be determined.

The eYenamic software was used to measure the activity level of animals, visible in the camera image, in real time and under practical conditions, i.e. in a pig pen. The activity level could be localised by measuring it for different pre-defined zones separately. An arbitrary number of zones could be defined interactively by the user as rectangular boxes in the camera image, defined by their upper-left and lower-right corners. For the experiments, the two pens visible in the camera images were each divided in two zones, covering the left and right hand side, respectively (figure 1).

Every second, the algorithm logged the camera image and the activity index for each zone that is defined as the fraction of the pen floor space covered or uncovered by the pigs in the camera image (i.e., the activity index is the fraction of the floor space that is 'moving'). The activity index for the four defined zones that was measured on-line during a 32 hour testing period on May 13-14 is shown in figure 2. The difference between day and night activity levels can clearly be noticed.

In collaboration with UNIMI, Milan, more quantities of continuous (24h/24h) video data and corresponding activity levels are currently being recorded. The analyses and results will be discussed during the workshop.

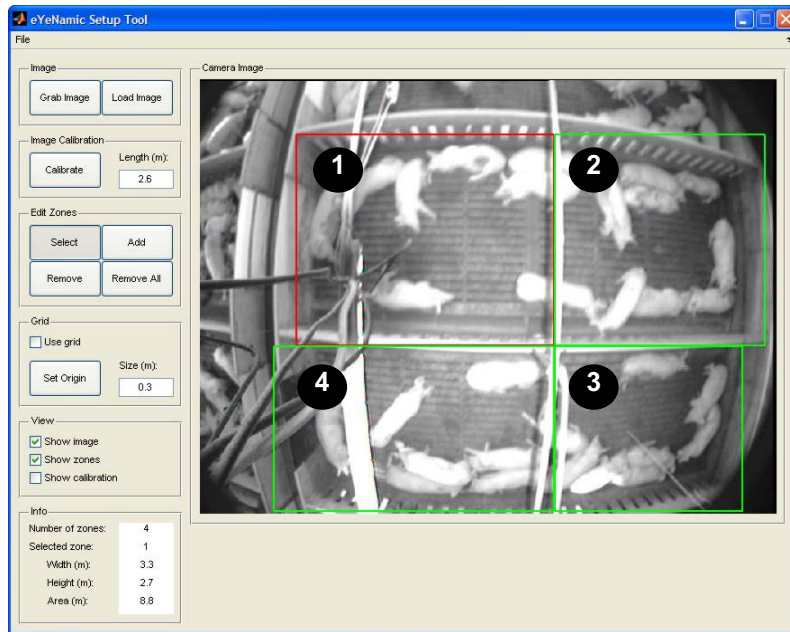

Figure 1: The eYenamic setup interface, showing the 2 x 2 zones that cover the left and right hand side of each of the two pens visible in the camera image.

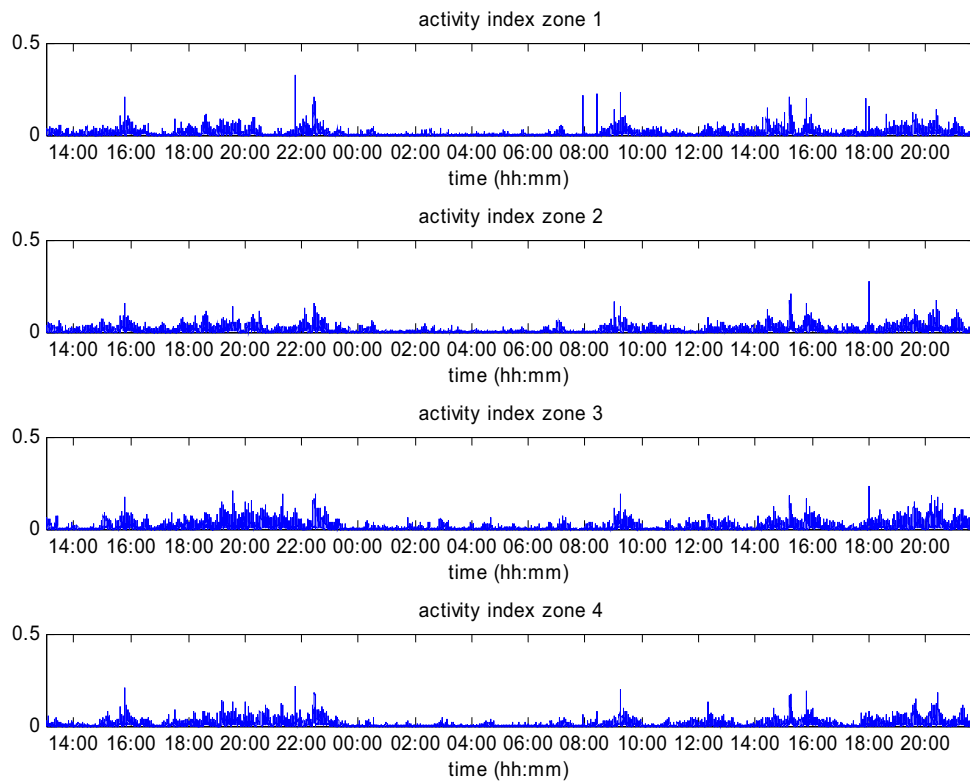

Figure 2: Activity index for the 4 defined zones during a 24 hour testing period

## SWINE WELFARE ASSESSMENT USING ANIMAL VOCALIZATION

†Naas I. A., Moura D.J., Silva W.T., Tolon Y.B. and Lima K.A.O.

Laboratory for Agricultural Buildings Research, Department of Rural Buildings and Environmental Control, State University of Campinas, Sao Paulo, Brazil  
e-mail corresponding author: irenilza@agr.unicamp.br

### INTRODUCTION

Animal vocalization analysis allows the potential to assess specific animal management parameters in a non-invasive manner. In addition the technique can facilitate individual animal identification. The goal of the analysis was to improve the health and welfare of a group of pigs, and ultimately to increase production efficiency (Jahns, 2004). In contrast to human language where meanings may change, animal vocalizations are usually produced according to fixed programs developed during phylogeny and achieved in ontogeny. Hence, with animals vocalizations are specifically attributed to particular inner states, with the exception of apes, where a more creative use might be possible under certain circumstances (Manteuffel *et al.*, 2004).

### OBJECTIVES

The objective of this specific study is the development of a system that registers and analyses the animals' sound emissions. This system uses as a reference the stress level pattern which the animals are submitted to, in order to make decisions about environment control. In this study the goal was to achieve the development of software to monitor, register and analyze swine vocal response.

### METHODS AND RESULTS

The computer program was designed in Delphi5. The sound was collected by a regular electret's microphone and an AMD 1200 256K RAM processor.

The swine vocalization signals used in the validation of this software were collected during the swine's nursery phase, with the intention of analyzing the animals' sound spectrum in stressful and non-stressful conditions. The swines' sound emissions were recorded in a notebook PC and later analyzed by the software that was designed to exclude environmental noise, human speech and pig vocalizations other than screams.

Figures 1 (a) and (b) illustrate the vocalization amplitude graphs converted into bytes, in relation to the time (s) for the non-stressful and stressful situations, respectively. The surface point polynomial adjustment of the sound waves emitted during the stressful situation and non-stressful situation are shown in Figures 1 (c) and (d), respectively. The spectrum analysis which is presented in Figure 1 (e) shows the non-stressful situations, while (f) shows the stressful situations. In this condition it can be seen different amplitudes for the stress and no stress situation. Figure 1 (g) and (h) shows the spectrum analysis screen, where there is the possibility of obtaining a full signal spectrum, through a Fourier Transformation. It is possible to see the five larger amplitudes for each frequency level. These levels are: 0 to 1000Hz, 1001Hz to 2000Hz, 2001Hz to 3000Hz, 3001Hz to 4000Hz, and 4001Hz to 5500Hz. It is possible to follow the time spectrum changes. The time collection of the principal frequencies is made in a 40 s interval analysis. Schön *et al.* (2004) reached a velocity of 6 resonance frequencies, in 46.44 ms duration. At this stage of development the software is in calibration phase, in order to transform the byte units into decibels.

### CONCLUSIONS

The software described in this study allows the analysis and interpretations of swine vocalizations in stressful and non-stressful situations, presenting distinct results on the characterization of the sounds emitted in both situations.

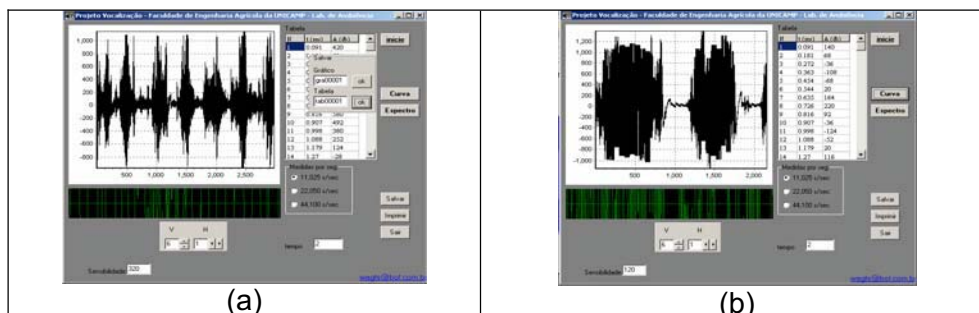

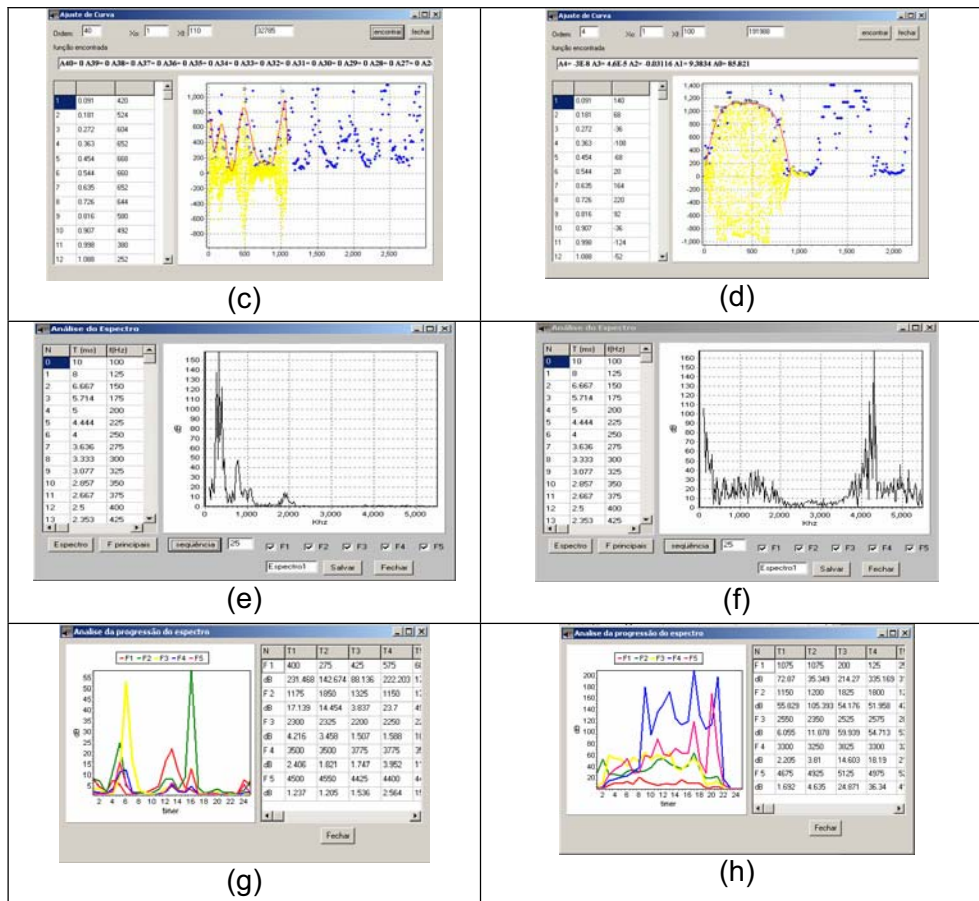

**Figure 1.** Vocalization amplitudes (a, b), polynomial adjustment (c, d), spectral analysis (d, e) and spectral analysis x time (g, h) for stressful and non-stressful situations respectively.

## REFERENCES

1. Jahns, G. Understanding Animal Vocalization. In <http://www.tb.fal.de/staff/jahns/animal.htm>. Accessed on 04/28/2004.
2. Manteuffel, G.; Puppe, B. and P. C. Schön. 2004. Vocalization of farm animals as a measure of welfare. *Applied Animal Behaviour Science* 88.163–182
3. Schon, P.C., Puppe, B. and G. Manteuffel. 2004. Automated recording of stress vocalisations as a tool to document impaired welfare in pigs. *Animal Welfare* 13, 105–110.

## AUTOMATIC DETECTION OF THE ONSET OF FARROWING

<sup>1</sup>Pastell M., <sup>2</sup>Oliviero C., <sup>1</sup>Hautala M., <sup>1</sup>Ahokas J., <sup>2</sup>Peltoniemi, O. and <sup>2</sup>Vainio, O.

*1 Department of Agrotechnology, University of Helsinki P.O BOX 28 (Koetilantie 3), FI-00014 University of Helsinki, Finland. 2Faculty of Veterinary Medicine University of Helsinki, P. O. BOX 57 FI-0014 University of Helsinki, Finland.*

*e-mail corresponding author: matti.pastell@helsinki.fi*

---

### INTRODUCTION

Several physiological parameters related to farrowing have been studied in sows. Some of these parameters are extremely interesting because they are clear signals of the approaching parturition. It is likely that by monitoring these parameters during the last days of pregnancy the onset of farrowing can be predicted. One of the clearest signals of approaching farrowing is increased activity due to nesting behaviour. Hartsock & Barczewski (1997) found that rooting, pawing, turning and walking behaviour increased during 12 hours prior to farrowing in sows kept in pens and crates. We have developed an activity monitoring system to measure the activity changes in sows kept in farrowing crates. The system consist of a force sensor measuring the movements of a sow and a photocell to detect whether the sow standing or lying.

### OBJECTIVES

We aim to develop technical means to measure changes related to farrowing and to develop an automatic alarm system that could alleviate farmers to precisely predict the onset of parturition. This would enable them to make better use of their working hours spent on the supervision of farrowing and to reduce losses at parturition.

### METHODS AND RESULTS

Three farrowing crates were equipped with an activity monitoring system. A thin film ferroelectric force sensor (Emfit) sealed between two rubber carpets was placed under the sows and photocells were placed next to the crate in order to detect whether the sow is lying down or standing up. The beam was placed so that the sow intercepted it while standing up and did not while lying down. Sows were placed in the crates a week prior to farrowing. The force sensors and the photocells were connected to an amplifier and the data was logged with a computer.

So far 9 farrowing have been monitored with the system and a clear increase in the activity of sows can be seen in all of the cases. The movements of the sows can be seen as peaks in the force sensors data (Figure 2) and standing up and lying down times in the data from the photocells. The data has been analyzed by counting the number of peaks from the force sensor and the duration of lying down and standing up and the frequency of getting up. Data from one farrowing is shown in figure 2. The data shows normal movement 3 days before farrowing and on the date of the farrowing. On the farrowing day the movement has been almost constant from 14 hours before farrowing to 4 hours before farrowing after which period the sow has remained almost stationary before parturition.

### CONCLUSIONS

The force sensor and the photocells can be used for monitoring the activity of sows in a farrowing crate and the increased activity before farrowing can be seen from the data. The results indicate that the onset of farrowing can be predicted with the system, perhaps connected to other physiological parameters like respiration rate and heart rate.

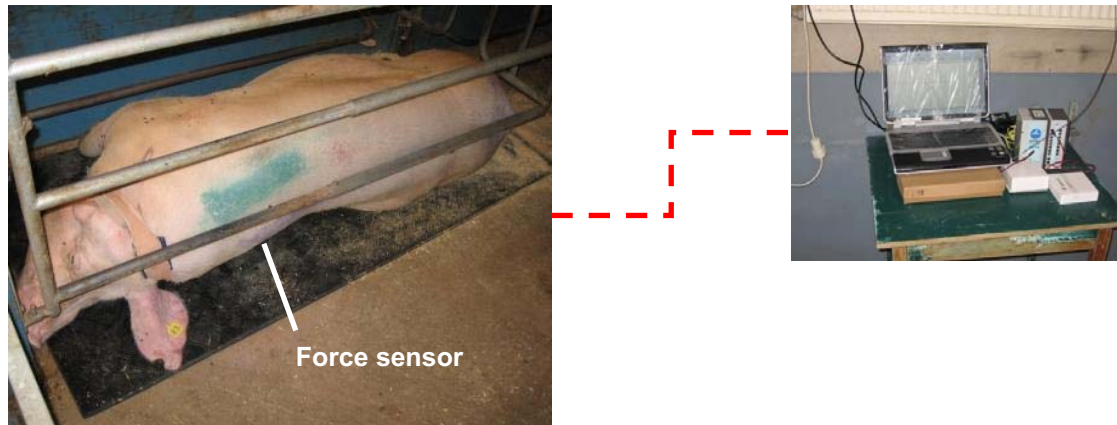

Figure 1. The force sensor under the sow and the data logging system.

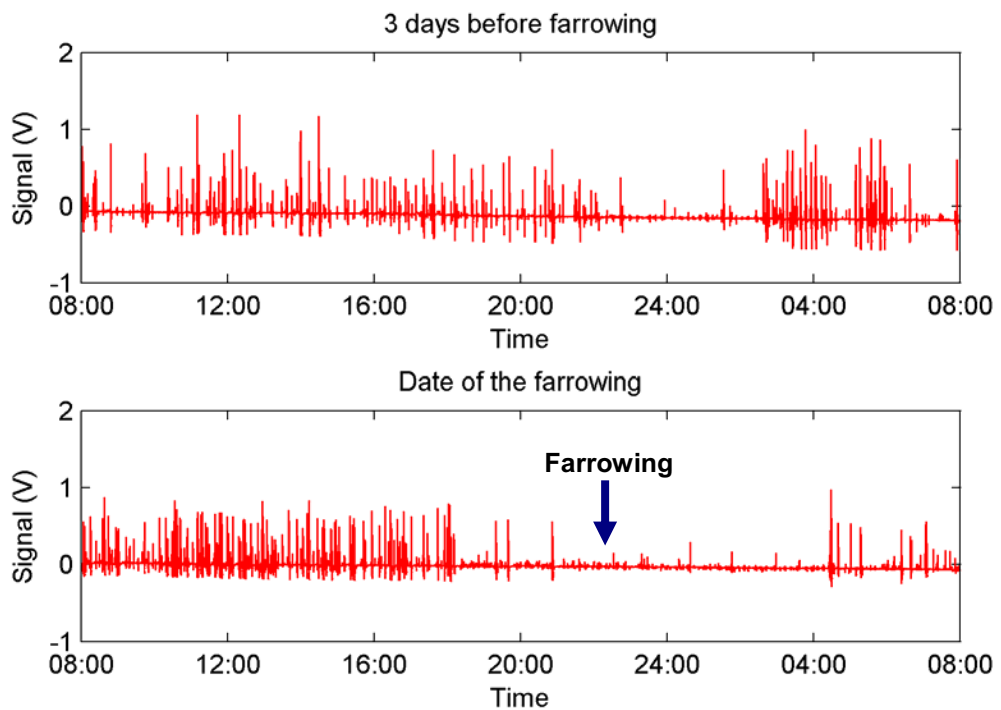

Figure 2. Raw data during 24 hours from the force sensor 3 days before farrowing and on the date of the farrowing,

## REFERENCES

1. Hartsock, T. G. and Barczewski, R. A. Parturition behavior in swine: effects of pen size. *Journal of Animal Science*, 75(11), p. 2899-2903.

## BEHAVIOUR SENSOR TO DETECT PHYSIOLOGICAL AND WELFARE STATUS FOR DAIRY COWS

<sup>1</sup>E. Maltz

<sup>1</sup>*Institute of Agricultural Engineering, A.R.O. The Volcani Center, P.O. Box 6, Bet Dagan, 50250, Israel  
e-mail corresponding author: emaltz@volcani.agri.gov.il*

---

### INTRODUCTION

Behaviour reflects the physiological status and well being of live stock. The latter is particularly significant in the absence of sensors and standards that clearly and quantitatively indicate livestock well being, which requires an animal to be free to exercise its natural behaviour. Our hypothesis is that a behaviour sensor can detect discomfort allied with housing (Livshin et al. 2005) or management constraints on the one hand, or diversion from normal behaviour related to physiological status on the other. A new telemetric behaviour sensor was recently introduced to the dairy industry (S.A.E. Afikim<sup>®</sup>, Kibbutz Afikim, Israel) which allows measurement of behaviour variables that, in addition to an ID tag and oestrous detection sensor, can be used to test the above hypothesis for dairy cows.

### OBJECTIVES

The general purposes of this study were: 1) to measure behavioural variables of dairy cows under hot climate conditions; 2) to study the way behaviour is affected by a management routine to reduce heat stress; and 3) to evaluate the possibility to use a behaviour sensor to indicate the onset of calving,

### METHODS RESULTS AND DISCUSSION

**Trial 1.** Seven pairs of cows were selected out of two neighbouring groups. Pairs were similar in parity, days in milk, milk yield and body weight. Each cow was fitted with a behaviour sensor that measures lying time, lying bouts and number of steps. The sensor's performance was checked against visual observations (Livshin et al. 2005). Data were downloaded every time the sensor was in the vicinity of an antenna (in our case located in each milking station). The normal summer routine is to move the cows between morning and noon and between noon and night milkings to the waiting area of the milking parlour and force-cool them (shower and fan successively) for 45-60 minutes. Measurements took place for 10 days after sensor fitting (period 1), then cooling ceased for one group (group B) and continued for one group (group A) for another 7 days (period 2). Behaviour data for each cow were averaged for each period and compared by paired t-test for the same cows between periods, and unpaired t-test between groups in each period. The daily routine was: 06:00 milking, 10:00 forced cooling, 11:00 feeding, 14:00 milking, 16:00 forced cooling, 17:00 scattered food nearing, 22:00 milking.

All the cows demonstrated outstanding stability of all the behaviour variables measured (Fig 1). Although there were quantitative individual differences between cows, the general pattern was the same.

The behaviour data are summarized in Table 1. There was no significant difference in behaviour between groups A and B during the two periods whether group B was forced cooled or not. A significant difference in morning lying time when comparing the same cows was revealed, showing about half an hour less lying time when forced cooled compared to not cooled. However, a similar difference can be seen in group A for which no management change was carried out between the two periods. This result reveals possible changes that occur "spontaneously", indicating the margins of behavioural variables that have to be taken into consideration despite them being rather stable. The reduced number of steps of the cows in group B in period 2 (the result of ceasing walking to the cooling area), with no difference between the groups in either period, can be the result of difference in walking distance. Lying bouts vary between individual cows (large SD) although they were very regular for individual cows, preventing significance in differences on this small number of cows. The average lying time in summer, diurnal and between milking, was similar to that measured during temperate periods (Livshin et al. 2005) under similar housing conditions.

**Trial 2.** Fifteen dry cows were fitted with behaviour sensors 10 days before expected calving. The dry cows were walked through the milking parlour once a day after noon milking (2:30 PM) to download the daily data. The data collected for complete 24 h prior calving was considered the day-before-calving, so, there were cows that the day-before-calving was 16-24 h before actual calving.

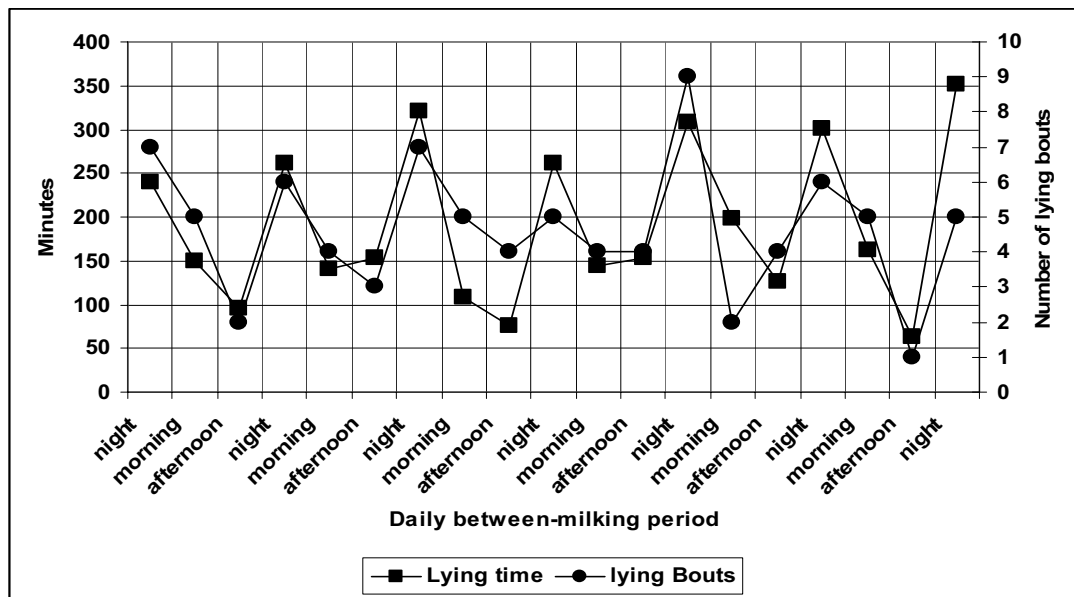

Figure 1. Lying time, and number of lying bouts in the between milking intervals of one cow during seven successive days.

Table 1. Behavioural variables of two groups of 7 cows during two periods (average  $\pm$  SD). One group (A) was forced cooled twice daily between milkings during both periods, and group B only during period 1. <sup>a</sup> (P<0.05) and <sup>b</sup> (P<0.01) - differences between cows of the same groups in different periods

Group Period Management	Day time	Lying time		Lying bouts		Steps	
		Minutes	% of Daily	Number	% of Daily	Number	% of Daily
Group A Period 1 Shower	Morning	118 $\pm$ 19 <sup>a</sup>	21.1 $\pm$ 2.7 <sup>a</sup>	2.9 $\pm$ 0.8	22.1 $\pm$ 4.6	811 $\pm$ 121	33.0 $\pm$ 1.5
	Afternoon	114 $\pm$ 33	20.3 $\pm$ 3.4	2.9 $\pm$ 0.8	22.1 $\pm$ 5.0	933 $\pm$ 166	37.9 $\pm$ 1.2
	Night	328 $\pm$ 33	58.6 $\pm$ 3.3 <sup>b</sup>	7.3 $\pm$ 1.6 <sup>a</sup>	55.8 $\pm$ 7.3	715 $\pm$ 149	29.1 $\pm$ 1.8
	Daily	560 $\pm$ 77	-	13.1 $\pm$ 2.6	-	2459 $\pm$ 419	-
Group B Period 1 Shower	Morning	97 $\pm$ 48 <sup>b</sup>	16.7 $\pm$ 7.7	3.7 $\pm$ 1.8	22.3 $\pm$ 8.1	966 $\pm$ 245 <sup>b</sup>	34.3 $\pm$ 6.5
	Afternoon	126 $\pm$ 38	21.6 $\pm$ 5.7	3.4 $\pm$ 1.3	20.5 $\pm$ 6.1 <sup>a</sup>	1100 $\pm$ 298 <sup>b</sup>	39.1 $\pm$ 4.8
	Night	359 $\pm$ 71	61.7 $\pm$ 12.5	9.5 $\pm$ 6.1	57.2 $\pm$ 10.0	748 $\pm$ 93	26.6 $\pm$ 3.4 <sup>b</sup>
	Daily	582 $\pm$ 54	-	16.6 $\pm$ 8.1	-	2814 $\pm$ 534 <sup>b</sup>	-
Group A Period 2 Shower	Morning	137 $\pm$ 28	23.7 $\pm$ 3.0	3.3 $\pm$ 0.8	22.3 $\pm$ 3.1	769 $\pm$ 120	31.9 $\pm$ 1.0
	Afternoon	122 $\pm$ 41	21.1 $\pm$ 4.6	3.2 $\pm$ 0.8	21.6 $\pm$ 5.7	924 $\pm$ 180	38.1 $\pm$ 3.5
	Night	320 $\pm$ 28	55.2 $\pm$ 4.3	8.3 $\pm$ 2.7	56.1 $\pm$ 9.6	727 $\pm$ 170	30.0 $\pm$ 3.7
	Daily	579 $\pm$ 83	-	14.8 $\pm$ 2.9	-	2419 $\pm$ 405	-
Group B Period 2 No shower	Morning	133 $\pm$ 43	21.9 $\pm$ 4.9	4.1 $\pm$ 1.9	21.8 $\pm$ 4.7	770 $\pm$ 229	32.4 $\pm$ 2.3
	Afternoon	138 $\pm$ 35	22.7 $\pm$ 2.5	4.3 $\pm$ 1.4	22.9 $\pm$ 4.5	888 $\pm$ 231	37.4 $\pm$ 2.6
	Night	337 $\pm$ 54	55.4 $\pm$ 6.7	10.4 $\pm$ 6.6	55.3 $\pm$ 6.5	716 $\pm$ 143	30.2 $\pm$ 2.1
	Daily	608 $\pm$ 103	-	18.8 $\pm$ 9.6	-	2374 $\pm$ 584	-

The difference in behaviour of each day was compared to the previous one (Table 2), as well as to the SD of 3 successive days (Fig 2). It can be seen (Table 2) that behaviour changes significantly during the last 24 hours before calving day. These differences are enhanced by calculated ratios (dividing diurnal lying time by number of lying bouts or the ratio of number of steps to lying time). The feasibility of behavioural variables and relations between them to predict calving well ahead is indicated by relating the daily differences to the STD of 3 days running AVG (Fig. 2). Most of the behaviour variables measured are exceptionally outstanding at the day before calving day.

Table 2. Diurnal averages of number of lying bouts, lying time, calculated lying time of one bout, number of steps, and number of steps to lying time ratio of 15 dry cows in the last seven days of pregnancy. P<0.05; \*\* P<0.01; \*\*\* P<0.001

Days before calving	Number of lying bouts	Lying time (min)	lying time of one bout (min)	Number of steps	number of steps to lying time ratio
7	17.1	721	47	2408	3.5
6	16.4	699	49	2670	4.4
5	18.6	674	54	2718	4.3
4	19.7	617*	43	2826	5.6
3	19.5	644	42	2690	4.5
2	17.9	627	43	2968*	5.1*
1	21.7	528**	30***	6858	13.3***

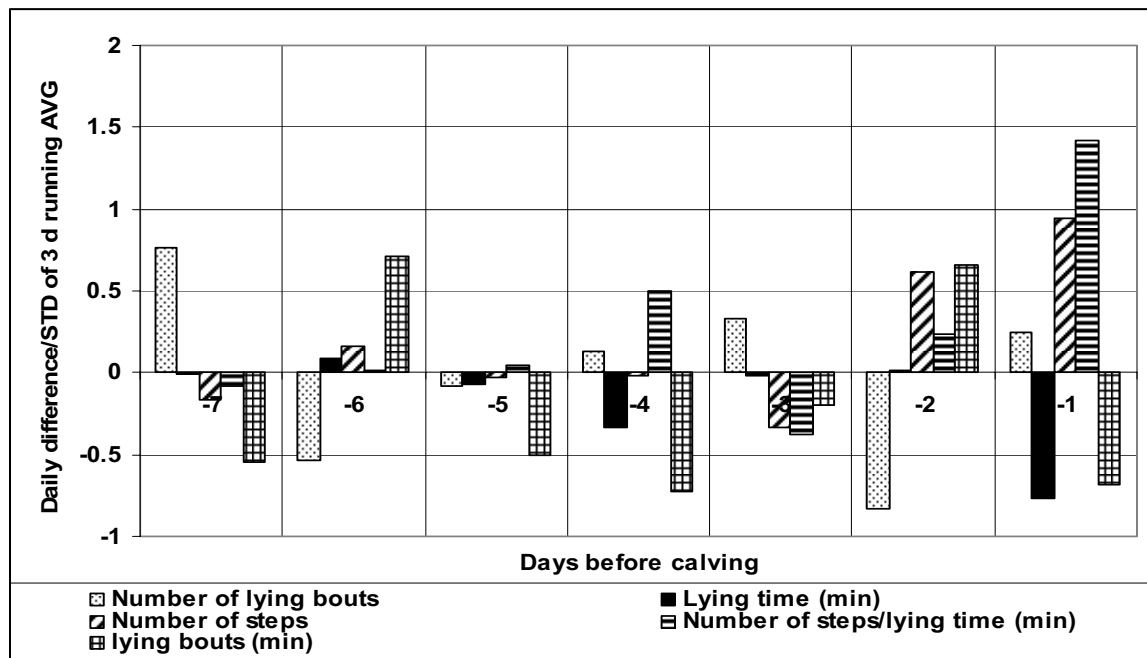

Figure 2. Daily differences between behaviour variables and relations between them related to STD of 3 d running average during 7 days before calving. At the day -1 (day before calving day) all, except number of lying bouts, are between 93 and 73 percent in the direction presented in the figure.

## CONCLUSIONS

The stability of the measured behaviour variables for individual cows as recorded in this work clearly suggests that behaviour variables can serve as well being indicators for dairy cows. Forced cooling cows for one hour twice daily during the summer does not impair quantitatively normal behaviour. The behaviour sensor can serve as an indicator for approaching calving.

### References

1. Livshin, N., A. Antler, B. Zion, G. Stojanovski, G. Bunevski, and E. Maltz (2005). Lying behaviour of dairy cows under different housing systems and physiological conditions Proc. Implementation of Precision Agriculture, 2nd ECPLF, 9-12 June 2005 in Uppsala, Sweden, pp. 305-311.



## **AUTOMATIC DETECTION OF LAMENESS IN CATTLE BY VISION**

Xiangyu Song, Toon Leroy, Erik Vranken, Daniel Berckmans

*Division Measure, Model & Manage Bioresponses (M3-BIORES), K.U.Leuven, Belgium*

---

### **INTRODUCTION**

Lameness is a continuing problem on dairy farms. Whether it is caused by physical injury, hoof disease or dietary nutrient deficiencies, lameness is a welfare issue and one of the most important health related economic losses in the dairy industry (Juarez et al., 2003). Early detection may prevent the cow's lameness from developing into a more serious problem which could affect the welfare and performance of the cow. However, solutions of successful early lameness detection have not been developed or implemented on the scale of modern commercial dairy farms (Clarkson, et al., 1996; Logue et al., 1998). Locomotion scoring is one of the methods to routinely monitor the overall lameness condition of a dairy herd. It is a qualitative index of a cow's ability to walk normally by visually scoring on the scale of 1 to 5, where score 1 reflects the sound cow and score 5 reflects the severely lame cow (Sprecher et al., 1997). Despite the significant use of locomotion scoring in the dairy farm recently, it is still time-consuming, subjective and requires great skill of the farmer who may have to score several hundred animals per day.

### **OBJECTIVES**

The objective of this research is to develop a method to automatically score lameness of dairy cows by analyzing the images that are taken when the animals walk normally.

### **METHODS AND RESULTS**

The experimental system was a 6 m long and 1 m wide passing alley located outside of the barn near the exit to the grass ground. Cows could walk through the alley in only one direction. A high speed camera was placed near the passing alley and fixed in 1.5 m high with a 10 degrees angle. When a cow was passing through the alley, the camera took a video with the side view of the whole cow's body. As a reference, locomotion of each cow was scored manually with the method of Sprecher et al. (1997). The recorded video was analyzed by a MATLAB program frame by frame. The cow's whole contour was subtracted by the background image. By image processing, the gravity centre of each hoof in each frame was found. After camera calibration, all the gravity centres with x-y coordinates in the real world were calculated. Figures 1 and 2 show two examples of walking situations of a sound cow and a lame cow, respectively. X (s) is the starting time when the cow entered the system. Y (pixel) is the distance of the hoof to the right edge of the image in the cow's walking direction of the alley.

### **CONCLUSIONS**

The locations of the sound cow's front and hind hoofs at the same side of the body (left/right) always have the approximately same Y value over time. On the other hand, there is a big difference between the Y values of the front and hind hoofs of a lame cow, and the hind hoof never locates on the same place as the front one on the same body side. Therefore, from these preliminary results, we conclude that there is a strong relation between the hoof locations and the locomotion scoring. Currently, further analysis is performed on data from more cows, covering the whole range of lameness. Analyzing cow's locomotion by vision can yield important information to detect the dairy cows' lameness automatically.

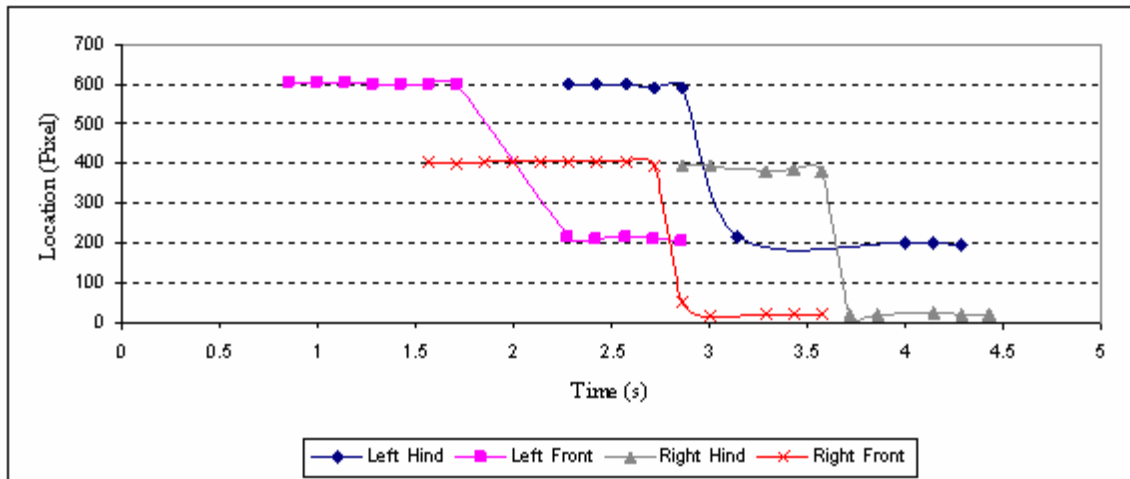

Figure 1. A sound cow's walking pattern in the system.

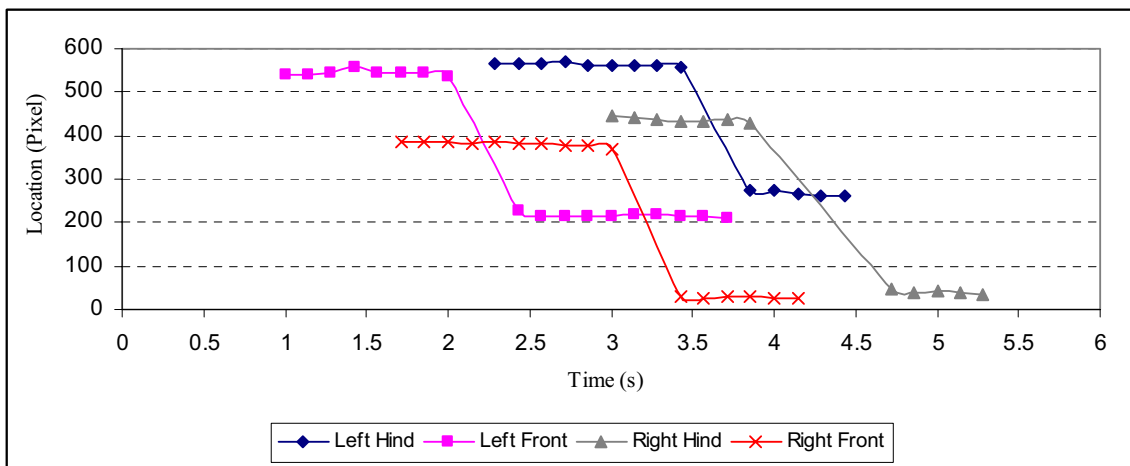

Figure 2. A lame cow's walking pattern in the system.

## REFERENCES

1. Clarkson, M.J., Downham, D.Y., Faull, W.B., Hughes, J.W., Manson, F.J., Merritt, J.B., Murray, R.D., Russell, W.B., Sutherst, J.E. and Ward, W.R. 1996. Incidence and prevalence of lameness in dairy cattle. *Veterinary Record* 138: 563-567.
2. Juarez, S.T., Robinson, P.H., DePeters, E.J. and Price, E.O. 2003. Impact of lameness on behaviour and productivity of lactating Holstein cows. *Applied Animal Behaviour Science* 83: 1-14.
3. Logue, D.N., McNully, D. and Nolan, A.M. 1998. Lameness in the dairy cow: pain and welfare. *Veterinary Journal* 156: 5-6.
4. Sprecher, D.J., Hosteller, D.E. and Kaneene, J.B. 1997. A lameness scoring system that uses posture and gait to predict dairy cattle reproductive performance. *Theriogenology* 47: 1179-1187.

## DETECTING COW'S LAMENESS IN A MILKING ROBOT

Matti Pastell<sup>1</sup>, Anna-Maija Aisla<sup>1</sup>, Mikko Hautala<sup>1</sup>, Väino Poikalainen<sup>2</sup>, Jaan Praks<sup>2</sup>, Imbi Veermäe<sup>2</sup>, Jukka Ahokas<sup>1</sup>

<sup>1</sup> University of Helsinki, Department of Agrotechnology, Department of Agrotechnology, Finland.

<sup>2</sup> Estonian University of Life Sciences, Department of Animal Housing Technology, Estonia

### INTRODUCTION

Limb disorders cause serious welfare, health and economic problems especially for cattle that are loose housed (Klaas et al, 2003; Juarez et al, 2003). There are only a few existing methods for lameness detection. Guard (Guard, 2004) states that the most commonly used method uses pedometers or activity meters worn around the neck. These systems are mainly designed for heat detection but they can also help detecting decreased activity levels caused by lameness. Rajkondawar et al. (Rajkondawar et al, 2002) have developed a lameness detection system which uses two parallel force-plates that measure the reaction forces of cow's limbs when a cow walks through the system. They concluded that the system could recognize lame animals and identify the affected limbs.

### OBJECTIVES

The purpose of this study is to develop a system to detect lameness in a milking robot. The system can be used in milking production to warn of possible leg problems.

### METHODS AND RESULTS

Automatic measurement of leg loads has proven to be useful in detecting leg problems. It can be used to characterize the comfort of the cow during milking through kicking behavior. (Pastell et al. 2006). An example of the automatically recorded leg load during milking is given in Figure 1. The mean values of the weight of each leg along with the standard deviation and number of kicks are automatically calculated after each milking.

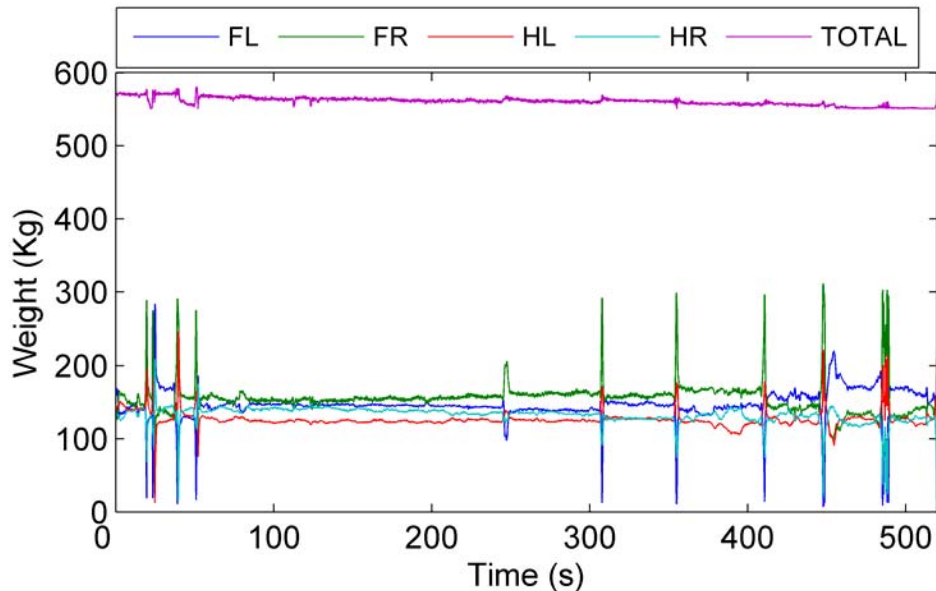

Figure 1. Leg load dynamics of a cow during one milking.

The system has proven to be useful in lameness detection. Lameness cases can be seen from the data as decreased weight on the affected leg and sometimes increased number of kicks due to constant lifting of the affected leg. Figure 2 shows data of the hind legs during 18 consecutive milking of a cow that has suffered from white line separation in the left hind leg, which has recovered after treatment. The day of the treatment can be seen from the data as decreased amount of kicking and stabilized leg weights as result of relieved pain. The weight data is handled as leg load index (LLI) that indicates the partial load of a leg in relation to the body weight.

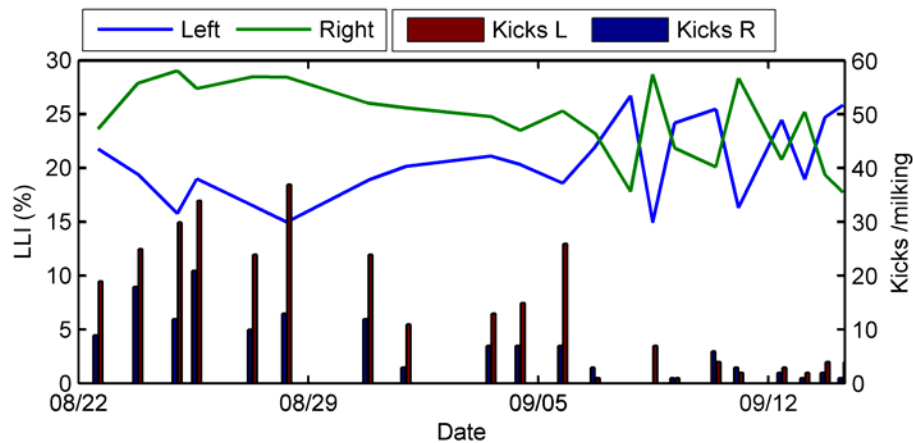

Figure 2. LLI's and the number of kicks per milking with hind legs of a cow during white line separation and after treatment.

## CONCLUSIONS

The measurement system has proven to be useful in lameness detection in a milking robot. Hoof diseases and other leg disorders can be seen from the data as lowered weight on the affected leg and sometimes also increased kicking frequency.

The durability of the system was a problem during the development of the detection system, but adding an extra sensor to the platform under the hind legs has fixed this. The system can be used to study the development of hoof diseases and to follow the effect of any treatment. We have also developed a probabilistic neural network model for automatically detecting leg problems with the system. The model is able to classify 96.2 % of the measurements correctly for healthy cows and cows with leg problems.

## REFERENCES

1. Guard, C. 2004. Animal Welfare and Claw Diseases. Proceedings of 13th International Symposium and 5th Conference on Lameness in Ruminants, edited by B. Zemljič. <URL: <http://ruminantlameness.com/end/proceedings2004.pdf>> pp. 155-158.
2. Juarez, S.T., Robinson, P.H., DePeters, E.J. and Price, E.O. 2003. Impact of lameness on behaviour and productivity of lactating Holstein cows. *Applied Animal Behaviour Science* 83 1-14.
3. Klaas, I., C., Rousing, T., Fossing, C., Hindhede, J., and Sørensen, J. T. 2003. Is lameness a welfare problem in dairy farms with automatic milking systems? *Animal Welfare* 12(4) 599-603.
4. Pastell M., Takko H., Gröhn H., Hautala M., Poikalainen V., Praks J., Veermäe I. Kujala M. & Ahokas J. Measuring Cow's Welfare: Weighing the Cow in a Milking Robot. *Biosystems Engineering* (2006) 93 (1), 81-87.
5. Rajkondawar, P.G., Tasch, U., Lefcourt, A.M., Erez, B., Dyer, R.M. and Varner, M.A. 2002. A System for Identifying Lameness in Dairy Cattle. *Applied Engineering in Agriculture* 18(1) 87-96. American Society of Agricultural Engineering.

## APPLICATION OF THERMAL IMAGING FOR CATTLE MANAGEMENT

U. Brehme<sup>1</sup>, D. Ahlers<sup>2</sup>, H. Beuche<sup>1</sup>, W. Hasseler<sup>2</sup>, U. Stollberg<sup>1</sup>

<sup>1</sup>*Institut für Agrartechnik Bornim e. V. (ATB), Max-Eyth-Allee 100, D-14469 Potsdam, Germany, E-mail: ubrehme@atb-potsdam.de*

<sup>2</sup>*Tierärztliche Hochschule, Klinik für Geburtshilfe und Gynäkologie des Rindes, Bischofsholer Damm 15, D-30173 Hannover, Germany*

---

### ABSTRACT

The main aims in this basic research project were to study the suitability of infrared techniques for detecting pregnancy and oestrus in dairy cattle and for identifying injuries and inflammations. We describe our preliminary results from a basic research project about the possibility of clinical application of infrared thermography for diagnostics in oestrus detection in dairy cows. This collaborative work between Veterinary High School in Hannover and Institute of Agricultural Engineering Bornim was started in summer last year with six dairy cows in a clinical study. All cows were synchronized and received an application with Prostaglandin F<sup>2</sup> three days after starting the investigation. With vaginal data logger we measured the body core temperature in an oestrus cycle to determine oestrus climax for best insemination. Our question was is it possible to identify the oestrus climax in the oestrus cycle with infrared thermography images from the temperature of the labia?

**Keywords:** dairy cattle, oestrus detection, infrared thermography, herd management.

(figures on page 28)

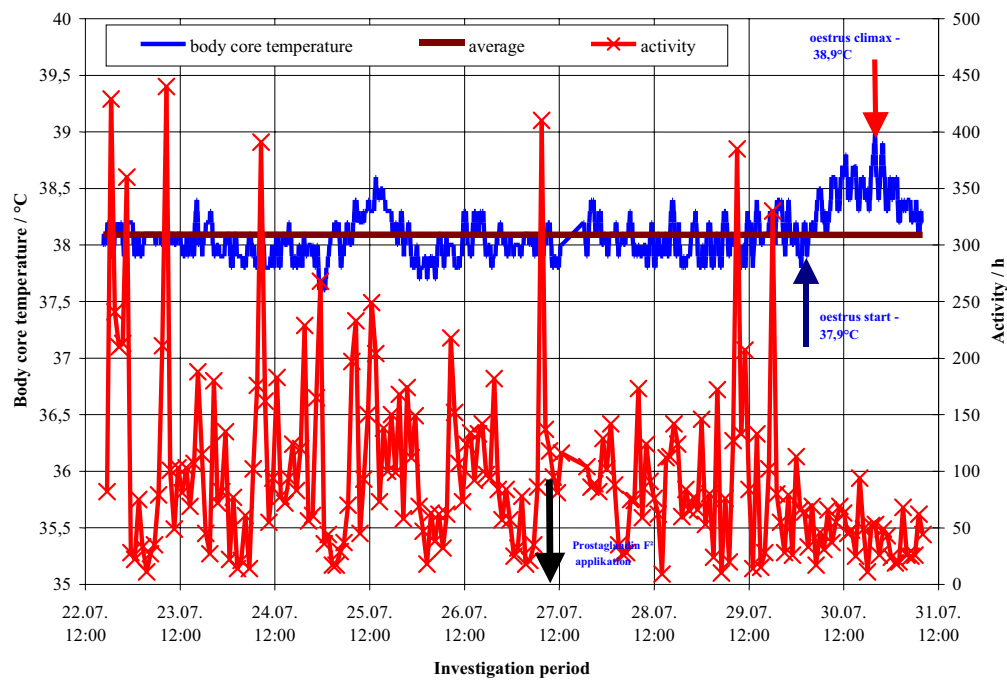

Figure 1: Result of measurements with data logger in vaginal tract

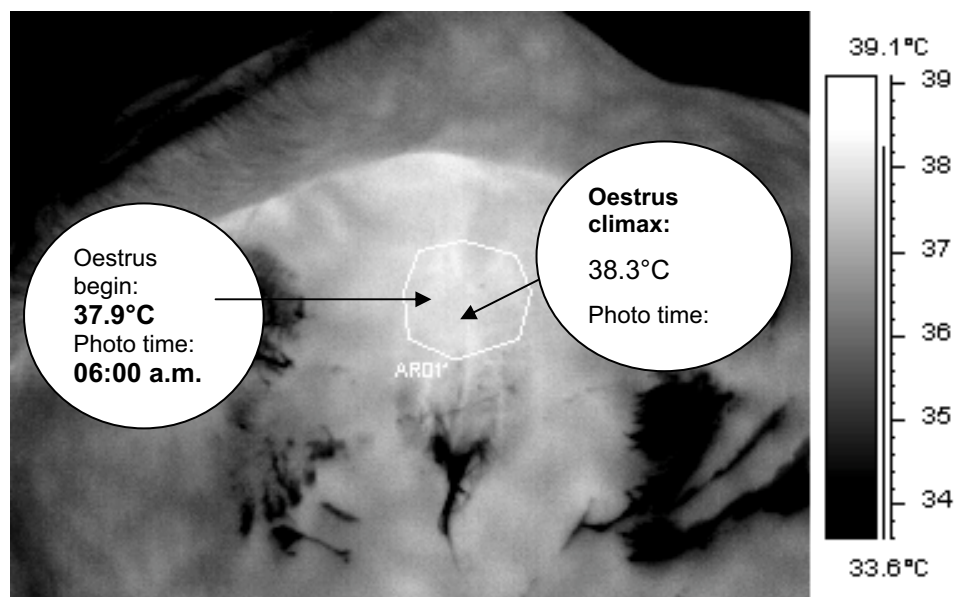

Figure 2: Results of body surface temperature with infrared camera as thermal profile of the external vaginal area (labia)

## MONITORING PASTURE TIME IN STRIPS OF NEW GRASS USING WIRELESS SENSOR NETWORKS

\*Nadimi E., Oudshoorn F., Bak T.

Research Centre Bygholm, Department of Agricultural Engineering, Schuttlesvej 17, 8700 Horsens, Denmark

\*e-mail corresponding author: [esmaeil.nadimi@agrsci.dk](mailto:esmaeil.nadimi@agrsci.dk)

---

### INTRODUCTION

Novel distributed wireless sensor networks provide data that allows monitoring of the motion of individual or herds of animals. Motion data would potentially benefit commercial farming by providing ways to monitor animal welfare in addition to automating and optimizing the production process. For example, the knowledge of the herd behaviour parameters (grazing time, position and the movement velocity of the animals in the field) is useful as a management tools in grazing optimization (Oudshoorn *et al.*, 2006).

### OBJECTIVES

The general purpose of this study was to measure the time length that dairy cows spent in strips of new grass using wireless sensor networks. Implementation of ZigBee as the wireless communication protocol was tested in order to aggregate the measured time length.

### METHODS AND RESULTS

The idea was to provide strips of new grass for cows and to monitor their behaviour in a rectangle shaped extended area. Each cow was equipped with a sensor node and the nodes formed a wireless sensor network. To measure time spent grazing, single hop routing characteristic of a wireless ad hoc sensor network was used. As the connectivity range of a base station is constant in all directions, the area covered by the base station will be a circle (Lewis, F.L., 2004). The base station was fixed on a moving fence; the area where the cows could move and communication with the base station was thus half of the aforementioned circle. To monitor how long each node (cow) spends in this half circle, the signal transmitted by each node contained a time stamp; therefore, the total time that the cows spent grazing, walking or were in other phases of their behaviour was measured in this half circle. The measured time is not an accurate indicator of the presence of cows in the extended area because the base station connectivity area (half circle) can be a different size than the extended area (rectangle).

The hypothesis that was used in this study to measure the time that cows spend in the extended area of new grass was based on a Bayesian probability function:

$$T_E = \frac{1}{p(A|B)} T_C \quad (1)$$

where  $p(A)$  is the probability of a node presence in the connectivity range of the base station and  $p(B)$  is the probability of presence in the extended area. The total time that the cows spent in the extended area was then quantified:

$$p(A|B) = \frac{p(A \cap B)}{p(B)} \quad (2)$$

where  $T_E$  presents the time that cows spent in the extended area (the strip of new grass) and  $T_C$  is the time registered by the base station when the nodes (cows) are in its range of connectivity.

To be able to verify the hypothesis, the whole process was recorded by a camera and data from wireless sensor network was compared with recorded events.

## CONCLUSION

A wireless sensor network was employed to measure the time that cows spent in an area of new grass. The results that were obtained by employing wireless sensor networks based on ZigBee protocol have been confirmed by the data registered by the camera and seem suitable to be used for the observation of cow behaviour while grazing.

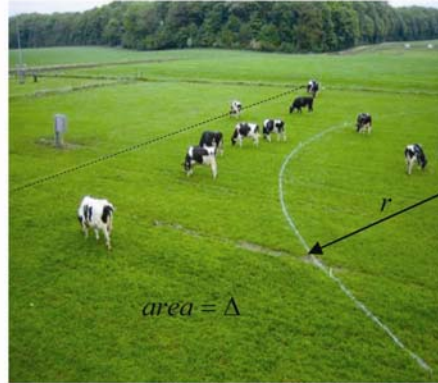

Figure 1. Connectivity range ( $r$ ) between base station and nodes; extended area ( $\Delta$ )

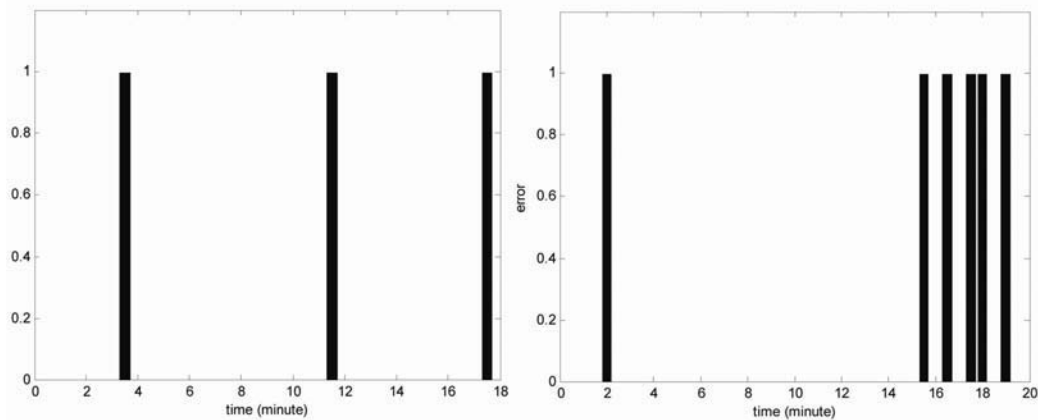

Figure 2. Error between the results obtained from the base station samples, and those obtained from the camera and both samples passed through a low-pass filter. Each bar indicates that, at that time interval, a cow was in the connectivity range of base station but it was not registered by wireless sensor networks

## REFERENCES

1. Lewis F. L. 2004. Wireless Sensor Networks. Smart environments: technologies, protocols and applications. John Wiley.
2. Oudshoorn, F.W., Kristensen T., Nadimi, E.S. 2006 - *in print*. Dairy cow defecation and urination frequency and spatial distribution in relation to time limited grazing. Submitted to Livestock Production Science.

## MODEL-BASED CALVING MONITOR USING REAL TIME IMAGE ANALYSIS

<sup>1</sup>Cangar Ö., <sup>1</sup>Leroy T., <sup>2</sup>Guarino M., <sup>3</sup>Fallon R., <sup>3</sup>Lenehan J., <sup>4</sup>Mee J. and <sup>1\*</sup>Berckmans D.

<sup>1</sup>*Division Measure, Model & Manage Bioresponses, Katholieke Universiteit Leuven, Kasteelpark Arenberg 30, B-3001 Leuven, Belgium*

<sup>2</sup>*Università degli Studi di Milano, Milano, Italy*

<sup>3</sup>*Teagasc, Grange Beef Research Centre, Dunsany, Co. Meath, Ireland*

<sup>4</sup>*Teagasc, Moorepark Dairy Production Research Centre, Fermoy, Co. Cork, Ireland*

\* e-mail corresponding author: [daniel.berckmans@biw.kuleuven.be](mailto:daniel.berckmans@biw.kuleuven.be)

### INTRODUCTION

The onset of parturition in bovines can be identified by the occurrence of particular behaviour activities such as an increase in the frequency of standing/lying, standing without eating or drinking and occurrence of prostrate lying (sideways with legs stretched). The stockperson uses such behaviours to monitor the progress of parturition and to decide if intervention is necessary to assist the cow.

### OBJECTIVES

The objective of this study is to develop a system that makes use of image analysis to identify calving behaviour in an automated way.

### METHODS AND RESULTS

In order to identify calving behaviour patterns five pens of nominal dimensions 4.6m X 3.3m were instrumented with cameras and recording equipment in the existing calving facilities at Grange Research Centre (Ireland). Two cameras were used on each pen (a) an overhead camera which generated a top view of the calving event and (b) a side view camera which generated the normal view of the calving event as seen by the stockperson. Images of cows approaching parturition were subsequently labelled at 10 second intervals (position in pen, lying or standing, type of lying, whether eating or drinking).

The camera images were analysed using a model-based method. After detecting the animal, a 2D model was fitted to its outline. This approach allowed a quantitative description of its body configuration along with its position and orientation with respect to the pen in the image. The model used is a flexible point distribution model where the output consists of 10 points at consistent positions along the outline of the animal (Figure 1).

The image analysis method was used on video images in an automated way by applying it to each subsequent image in the video sequence. The resulting output of the method when applied to a video sequence consisted of the animal's position, orientation and body configuration as a function of time. Using these outputs, calving behaviours such as distance walked, orientation, standing/lying, eating/drinking behaviour can potentially be identified.



Figure 1. Screenshot of the image analysis output and the 2D model used. The model output consists of 10 points at consistent positions along the outline of the animal.

A change in standing/lying behaviour is an important indicator of the progress of parturition. An example of the method of analysis to automatically indicate such behaviour patterns is presented for a one hour video sequence of a cow, recorded on 19/03/2005 from 02h00-03h00. The cumulative distance walked starting from 02h00 is plotted as a function of time in Figure 2. Standing periods could be differentiated by the steep increase in the cumulative distance walked. While there should be no accumulation of

distance walked during lying, the slow increase recorded is due to the limited amount of movement that the cow makes when recumbent.

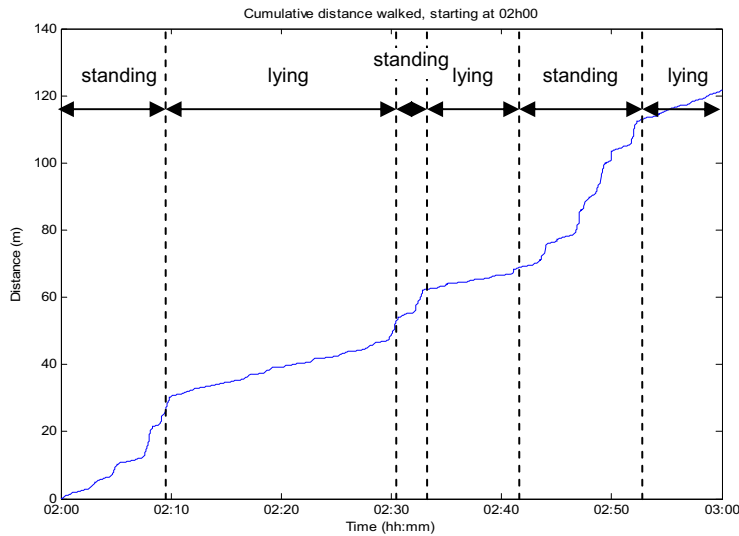

Figure 2: The cow's cumulative distance walked in meters on 19/03/2005 from 02h00 to 03h00 as a function of time. The manual reference labelling of standing/lying behaviour is indicated.

A second method to identify the standing/lying times uses changes in body width to length ratio. The classification was performed by applying a threshold on a moving average of the measured body width/length ratio. The outcome was plotted as a function of time in Figure 3. Applying a more accurate threshold and/or combining the data in figures 2 and 3 can improve the precision in detection of lying or

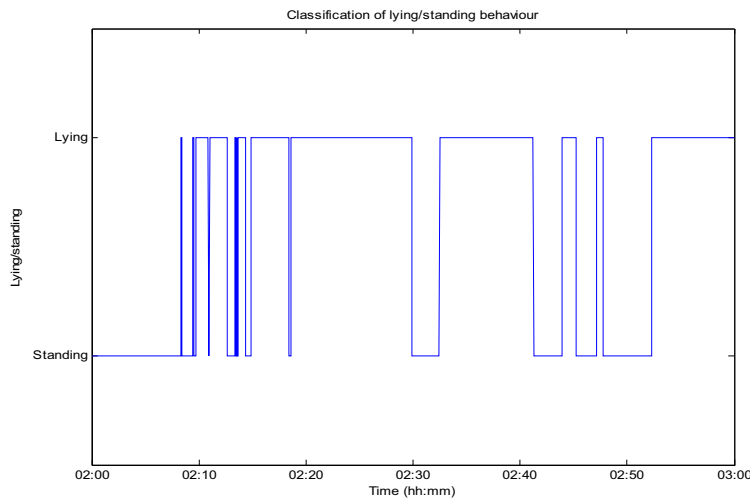

Figure 3: The automatic classification of lying/standing behaviour on 19/03/2005 from 02h00 to 03h00 as a function of time. The manual reference labelling of standing/lying behaviour is indicated.

## CONCLUSIONS

The potential for using image analysis in the development of an automatic calving monitor has been identified. Research is continuing to refine the model and to establish consistent behaviour patterns which best indicate the stage of parturition and that can be automatically detected.

## **A NOVEL TEST CHAMBER FOR LABORATORY MICE**

AR Green, CM Wathes, TGM Demmers, J MacArthur-Clark, H Xin

---

A novel test chamber was designed to assess the aversion of laboratory mice to ammoniated atmospheres. The chamber consisted of four individually ventilated compartments in a three dimensional arrangement. Each compartment was connected to the other compartments via access tunnels and every compartment was accessible from every other compartment.

The ventilation was provided for each compartment by a separate fan, and ammonia was injected into the supply duct to achieve the desired concentration. Ammonia concentration was sampled at the exhaust of each compartment. The ventilation system was designed to provide a minimum of 100 ACH with a maximum velocity of  $0.1\text{ms}^{-1}$  and maintain laminar flow within each compartment.

The chamber was equipped with a tracking system, consisting of IR sensor pairs and photosensors located within the tunnels. The tracking system sensors were connected to IC's: 74ALS373 D-type Octal Latches and MPC5088 Channel Analog Multiplexers, respectively. The IC's were interfaced with a PC via PMD 1208-LS. The interface code was written in VBA and operated with Excel.

The resulting data set was a collection of binary digits. An algorithm was used to translate the binary data to specific movements between compartments. The translated movements were then compared to video for confirmation, and to address any movements unidentified by the tracking system.

This paper discusses the chamber and tracking system design and performance in an initial preference test.

## MONITORING OF SWARMING SOUNDS IN BEE HIVES FOR PREVENTION OF HONEY LOSS

Ferrari S., Silva M., Guarino M. and Berckmans D.

- <sup>1)</sup> *Measure, Model and Manage Bioresponse (M3-BIORES), Department of Biosystems, Katholieke Universiteit Leuven, Kasteelpark Arenberg 30, 3001 Heverlee, Belgium;*  
<sup>2)</sup> *Dipartimento de Scienze e Tecnologie Veterinarie per la Sicurezza Alimentare, Facoltà di Medicina Veterinaria, Università degli Studi di Milano, Via Caloria 10, 20133 Milano – Italy;*

Beekeeping, one of the oldest forms of agriculture, is following the evolution of human technology, and in its complexity there is increasing need to control honey production with what modern technology can offer. In the view of animal production, honey is included since the farmer has interest in producing large quantities of honey according to the best blooming time, presence of parasites, genetic strain of his bees and swarming periods of the honeybees (queen and her workers leaving the hive). This last fact has a big economic ramification for the beekeeper as swarming means honey loss when the bees start collecting the honey to migrate. Hence a method that enables the prediction of the swarming is highly desirable to prevent the queen from leaving the hives.

In this experiment an acoustic method is proposed to predict the swarming period. Three hives were monitored for 200 hours. The microphones were placed inside the hives together with a temperature and humidity sensor. The sound was recorded at a sampling rate of 2 kHz, and analyzed via Matlab and Cool Edit Pro. During this period four swarming activities occurred. Prior to an increase of swarming there is a decrease in the sound energy from approximately -86dB to approximately -80dB, after which it increases again to approximately -75dB (fig. 1, where the arrow indicates beginning of swarming). There is an increase in the power spectral density at about 110Hz, 240Hz, 400Hz and 650Hz. Most spectacular changes occur at 200Hz, 400Hz and beyond 650Hz (fig. 2). Another finding indicating initiation of a swarming period is the increase in temperature from 33 °C to 35 °C until the actual time of swarming, when the temperature drops again to 32 °C (fig. 3). As there is less noise produced by the bees, one can assume that they are ventilating less, leading to temperature increase in the hive. Once more activities resume with the commencement of swarming, the ventilation causes the temperature to drop. The temperature during swarming is shown in Figure 4 (indicated with the thick line). The increase in temperature, together with the changes in acoustical features of the sound recorded in the hive, may be used as a predictor for swarming of the bees which in turn may be used as a management tool for reducing honey loss.

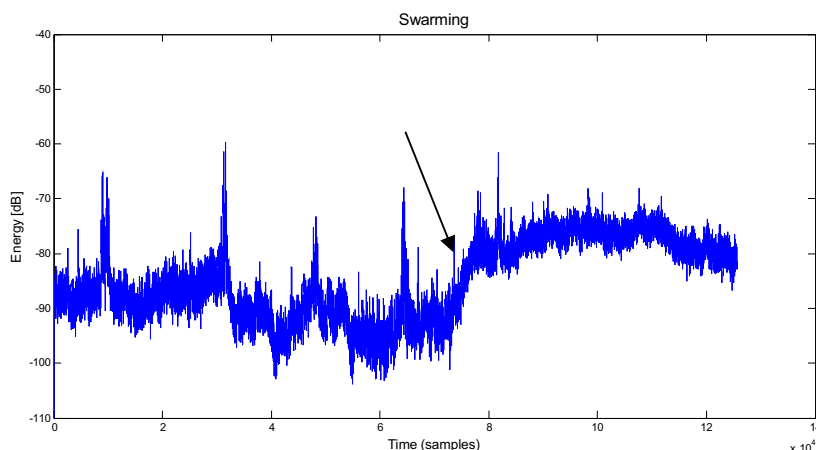

Figure 1: Change in sound intensity over time. The arrow indicates the beginning of swarming.

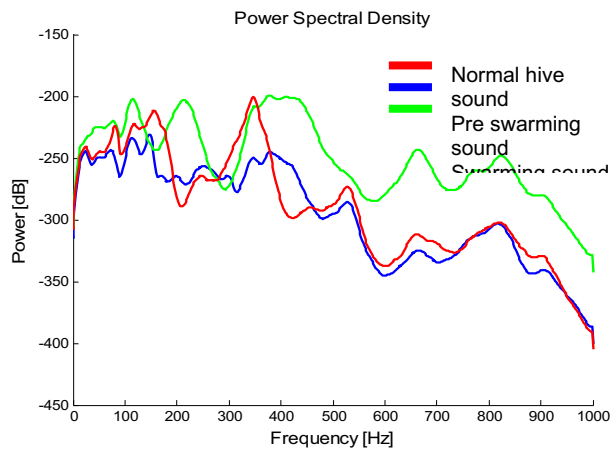

Figure 2: Power spectral density of 3 sound signals: a) during normal day activity (normal hive), b) prior to swarming (pre swarming sound), and c) during swarming (swarming sound).

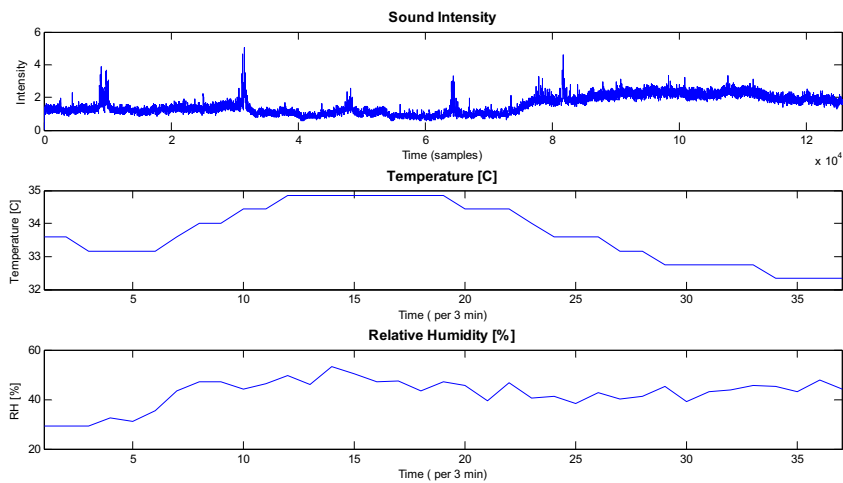

Figure 3: Temporal profiles of sound intensity, air temperature and relative humidity inside the bee hive. Prior to swarming there is an increase in temperature, once swarming has begun there is a decrease in temperature.

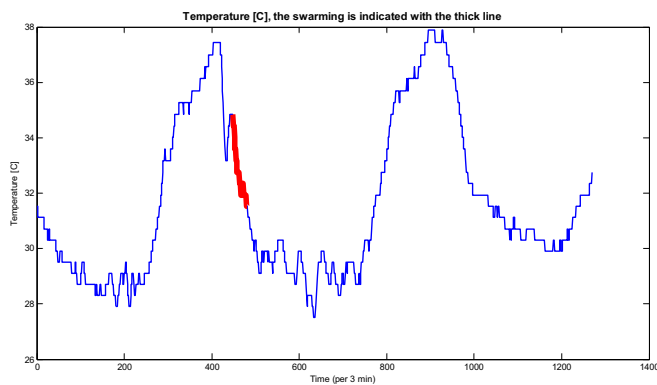

Figure 4: Temporal profile of air temperature inside the bee hive over 63 hours. The thick line corresponds to the swarming period.

## **A NEW EXPERIMENTAL FACILITY FOR ANIMAL WELFARE AND PRECISION LIVESTOCK FARMING RESEARCH**

\*Demmers T.G.M., Lowe J.C. and Wathes C.M.

*Centre for Animal Welfare, Department of Veterinary Clinical Sciences, The Royal Veterinary College,  
Hawkshead Lane, North Mymms, Hatfield, AL9 7TA, United Kingdom  
\*e-mail corresponding author: tdemmers@rvc.ac.uk*

---

### **INTRODUCTION**

A new Centre for Animal Welfare has been established at the Royal Veterinary College, University of London. The aim of the Centre is to undertake fundamental and strategic research on the environmental biology underpinning the welfare and management of farm and laboratory animals. The Centre's research focuses on: (i) the perceptual and cognitive processes in farm and laboratory animals, and behavioural and physiological responses to their physical and social environment; and (ii) development of engineering systems to monitor animal welfare and manage the animal's environment with an emphasis on precision livestock farming.

### **NEW FACILITY**

To facilitate the research of the Centre, a new animal welfare laboratory has been designed and built. The laboratory comprises 10 identical rooms (each 5.6 m x 3.5m), two (cross) sections of a livestock building (each 15.2m x 5.5m) and an environmental laboratory and control room. Each room can hold 240 broiler chickens or 24, 100 kg pigs while each section can hold 1100 broilers or 96, 100 kg pigs. The rooms have a solid floor with a drain for liquid run-off, while the two cross sections are partially slatted, but can be easily converted to a solid floor. Each room can be used as a holding area for animals, such as calves, sheep, poultry and pigs, an experimental room or a laboratory for experimental equipment. The environmental management of the building and feeding the animals is fully automated. Light, ventilation rate, heating, temperature, humidity (increase only) can be manipulated independently and aerial pollutant concentrations (notably ammonia) can be increased artificially. Continuous measurements can be taken and recorded in each room for environmental and livestock production and animal behaviour parameters.

### **PRECISION LIVESTOCK FARMING**

The animal welfare laboratory will in particular support our research into new integrated management systems for livestock. Our three broad objectives are: (i) to determine the steady-state and dynamic responses of behaviour, growth and aerial pollutant emissions from pigs and fowl by separate and combined manipulation of light intensity, protein levels in the diet, and, absolute humidity or ventilation rate; (ii) to devise mathematical models of these interactions; and (iii) to demonstrate the principles of control systems to manage the physical and social environment of livestock. The design of the first experiment with broiler chickens to satisfy this first objective is described and illustrates the scientific and engineering challenges in conducting PLF experiments.

## COMPUTER VISION SYSTEM TO EVALUATE PIGLETS WELFARE

\*Naas I.A., Moura D.J., Silva W.T., Mendes A.S. and Lima K.A.O.

Laboratory for Agricultural Buildings Research, Department of Rural Buildings and Environmental Control, State University of Campinas, Sao Paulo, Brazil  
\*e-mail corresponding author: irenilza@agr.unicamp.br

---

### INTRODUCTION

Computational vision techniques are being successfully used in animal behaviour studies and to evaluate their welfare. Since the 1980's image analysis techniques have developed rapidly. One of the main characteristics of these techniques is that it allows the animal identification in a non-invasive and remote way. The use of image analysis permits the automatic identification of the occurrence of different situations and behaviours related to stress, reproduction and sanitary conditions that may be useful for research as well as for production management. Several researchers are studying automated systems using image analysis techniques in animal production with positive results (Shao *et al.*, 1998; Sergeant *et al.*, 1998; Hu & Xin, 2000).

### OBJECTIVES

This research had the objective to develop an algorithm using computational vision, to recognize animal behaviour data and identify piglet's thermal comfort and welfare status.

### METHODS AND RESULTS

The computer program was designed in Delphi5. Basically, the image was transformed in colour (red, green and blue) levels (from 0 up to 255), whose values were recorded in the program memory. The interval of the levels were: red (0 up to 90), green (90 up to 120) and blue (120 up to 255), without restriction in saturation or intensity.

The values were recorded pixel by pixel. The reading of the pixels was made line by line to complete the whole figure. When a pixel was found inside the desirable colour level, it was recorded in a table, with its coordinates (x,y) and colour level in bytes.

After the recognition of all points, the animal's centre of mass was calculated and also the distance of each pixel to its centre of mass. With this data, it was possible to get other information, such as the average velocity of the centre of mass dislocation  $V(c)$ , the dispersion and the average velocity of dispersion  $V(\text{disp})$  of figure points. The area occupied by each piglet was found by adding the selected pixels.

The software was validated in a commercial swine farrowing house located at Elias Fausto city, state of São Paulo where the pigs' images were taken.

Figure 1 shows the piglets' image and the centre of mass of each animal which is automatically calculated by the software. In Figure 2 the software identifies the important points through the limits of programmed colours. Figure 3 shows the searched and registered centre of mass and Table 1 shows the values of the centre of mass coordinates  $C(x)$  and  $C(y)$ , the dispersion of the animals and their occupied area. In all cases the values are not in standard distance unity (m), but in proportional values.

Where the animals presented the highest value of dispersion combined with a high occupied area may indicate an environment with hot status. Where the animals presented the least value of dispersion combined with a high occupied area may indicate that the animals have a good comfort status. On the other hand, Figure 1 presented the smaller occupied area but a medium value of dispersion which can indicate an environment with cold status. A database of behaviour images associated to climatic variables need to be build to evaluate this data with more precision.

## CONCLUSIONS

It was possible using image analysis to characterize different piglet's behaviour patterns inside the farrowing house facilities, based on the dispersion of their centre of mass in different environment conditions. The software need to be improved by making a data base to be modelled in a neural network procedure, turning the decision making more accurate in the climate control processes



Figure 1 – Visualization of the animals' centres of mass.

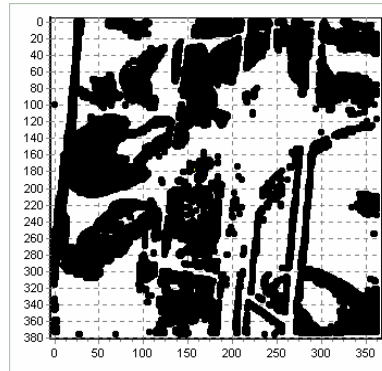

Figure 2 – Image segmentation

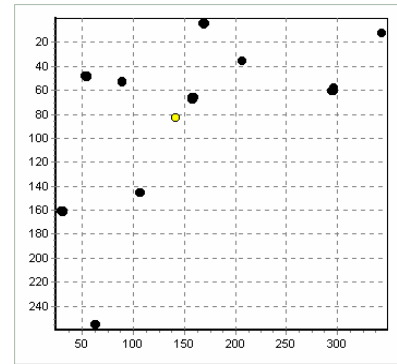

Figure 3 – animals' centres of mass graphically plotted.

**Table 1** - Centre of mass coordinates, velocity of dislocation, degree of dispersion, and dispersion velocity.

Piglet	C (x)	C (y)	V(C)	Dispersion	V(disp.)	Area
1	146,4	77,7		99,54		36
2	121,5	90,7	28,05	111,63	1,209	37
3	155,7	70,6	39,63	109,67	-0,196	37
4	154,3	104	33,44	126,63	1,696	51
5	128,9	80,1	34,88	83,26	-4,337	51
6	159	55,4	38,95	76,69	-0,657	52

## REFERENCES

1. Hu, J. and H. Xin, H. 2000. Image-processing algorithms for swine postural behaviour analysis. *Behaviour Research Methods, Instruments & Computers*. 32 (1): 72-85.
2. Sergeant, D., Boyle, R. and M. Forbes. 1998. Computer visual tracking of poultry. *Computers and Electronics in Agriculture*. 21:1-18.
3. Shao, J., Xin, H. and J.D, Harmon. 1998. Comparison of image feature extraction for classification of swine thermal comfort behaviour. *Computers and Electronics in Agriculture*. 19: 223-232.

## LEIA: LOW-END IMAGE ANALYSIS TO CONTINUOUSLY MONITOR GROWTH AND BODY CONFORMATION OF FATTENING PIGS

<sup>1</sup>\*Appel C., <sup>1</sup>Jungbluth T. and <sup>2</sup>Hartung E.

<sup>1</sup>Universität Hohenheim, Institute of Agricultural Engineering, Garbenstrasse 9 - 70599 Stuttgart, Germany

<sup>2</sup>Christian-Albrechts-Universität zu Kiel, Max-Eyth-Str. 6 - 24118 Kiel, Germany

\*e-mail corresponding author: cappel@ilv.uni-kiel.de

### INTRODUCTION

An increasing demand for improved management capabilities caused by larger herd and group sizes, and statutory requirements on documentation and traceability, magnifies the shortfalls which presently can be found in many processes in livestock production (Frost *et al.*, 2004). Optimized tools to improve livestock production with respect to management and economic issues should provide process-relevant information at relevant stages during the course of production.

To collect process-relevant information like animal weight and body conformation both continuously and in real-time, hands-off methods utilizing 2D image analysis show great potential, e.g. to derive dynamic growth models to optimize nutrient utilization (Whittemore, 2004) or to monitor meat quality and body conformation (Doeschl-Wilson *et al.*, 2005; White *et al.*, 2004). The information gathered can be used to support management decisions like culling, shipping or medical treatments (Van der Stuyft *et al.*, 1991). Development of commercial optical sorting scale systems utilise the technique (Cielejewski *et al.*, 2005).

### OBJECTIVES

Monitoring pigs within a pen is still an on-going development. Most of the approaches mentioned feature complex image analysis algorithms which are specific to different breeds or genetic strains (White *et al.*, 2004). Moreover, in the case of fattening pigs it is crucial to know a group's heterogeneity in terms of weight and conformation quite early. Therefore, this project's aim is to provide a generic methodology to continuously monitor and quantify the differences of growth and body conformation (heterogeneity) within a group of animals using a set of robust and simple, i.e. low-end image analysis (LEIA) algorithms. The methodology will be breed-independent and is verified under practical conditions with fattening pigs.

The project will provide non-dimensional parameters to describe a group's heterogeneity with regards to changes in time. These parameters will be deployable by the user to increase transparency and traceability of the whole production process.

### METHODS

An image acquisition system was installed in a research stable with four equal-sized pens (3.3 x 7.8 m<sup>2</sup>) in two compartments holding 30 pigs each (average weight range observed: 30 kg to 120 kg).

The system comprised analogue b/w cameras which were mounted to provide a top-view within a single pen: two cameras to cover the pen area and one camera observing the trough region. Another camera was mounted perpendicularly over a separate weighing scale. Analogue frame-grabbers were used to record image data on a regular PC system utilizing proprietary image-recording software.

**Table 1:** Trial time schedule

	Trial Week														
	0	1	2	3	4	5	6	7	8	9	10	11	12	13	14
<b>Weighing and assessment</b>															
<b>Image sequences</b>															
- Trough camera															
- Pen cameras															

As a reference for geometric features derived from image sequences, the weight of each pig was collected along with other parameters describing the individual's body conformation and its overall fitness (assessment). During each animal weighing and assessment, an image sequence of the pig in the scale was collected. Each day after all pigs were weighed and assessed, image sequences from cameras in the pen were recorded in daytime (5:45 – 22:15). This enables the comparison of geometric features from image sequences from both pen and weighing scales with the manually assessed parameters.

## RESULTS

Animal weighings and assessments were performed ten times. Ten single days of trough camera sequences were recorded along with four days of each of pen cameras resulting in over six million single images being available. Image sequences were linked into an extensive database (LEIA/DB) containing image data, image analysis data and over 1500 animal assessment data sets (weight, body conformation scores).

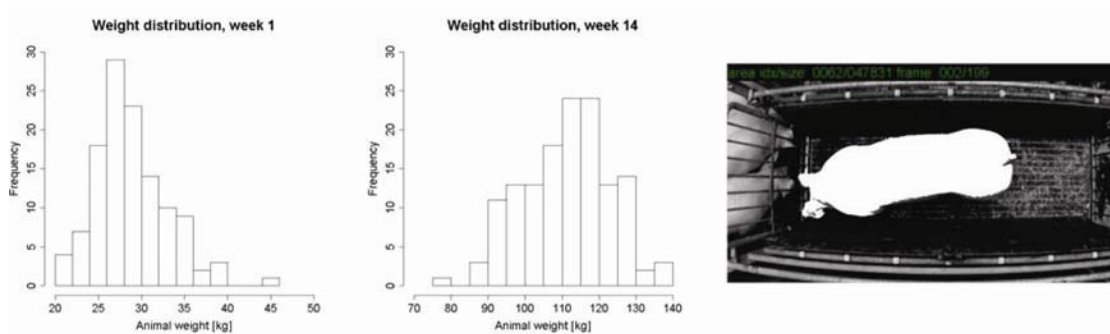

**Figure 1:** Development of the overall animal weight distribution (trial week 1 vs. 14, n = 120)

**Figure 2:** Automatically detected pig; weighing scale camera

The development of the overall animal weight distribution suggests a notable heterogeneity from start until finish of the fattening period. Further research has to show whether pigs with low or high weight keep their individual outlier-position in terms of weight or daily weight gain in the course of the whole fattening period. Currently, scale image sequences are segmented using the Isodata algorithm. As a result, each scale image sequence provides a data set of 200 values referring to the back area or other geometric features to be tested, e.g. length or width. In a first step, different methods are applied to gain one single representative value (SRV) per sequence for the detected back area or the respective geometric feature to be tested. The resulting distributions of SRV for a group of pigs will then be compared against the animal weight distribution of each analyzed group. More detailed results will be available to be presented at the workshop.

## REFERENCES

1. Frost, A.R., D.J. Parsons, K.F. Stacey 2004, Integrated Livestock Management Systems - Research Priorities and Progress, in Proceedings of the AgEng Conference. 2004, Technical Institute, KU Leuven: Leuven, Belgium.
2. Whittemore, C.T. 2004, Production Control Systems for Pigs, in London Swine Conference. 2004, London, Swine Conference: London, USA. p. 111 -118.
3. Doeschl-Wilson, A.B., D.M. Green, A.V. Fisher et al. 2005, The relationship between body dimensions of living pigs and their carcass composition, in British Society of Animal Science Annual Conference. 2005, Penicuik, UK: British Society of Animal Science: York, UK.
4. White, R.P., C.P. Schofield, D.M. Green et al. 2004, The effectiveness of a visual image analysis (VIA) system for monitoring the performance of growing/finishing pigs. *Animal Science*, 2004. 78(3): p. 409-418.
5. Van der Stuyft, E., J. Van Bael, V. Goedseels et al. 1991, Design of a procedure yielding a standard posture in live pigs for computer vision-based exterior shape measurement, in 1st International Seminar for the Agricultural and Bio-Industries. 1991: Montpellier, France. p. 99-101.
6. Cielejewski, H., E. Tholen, K. Geerdes et al. 2005, Test of applicability of the videosystem optiSORT (de-veloped by Hölscher+Leuschner) to determine the weight and the carcass quality (in terms of AutoFOM) of fattened pigs, in Bau, Technik und Umwelt in der landwirtschaftlichen Nutztierhaltung. 2005, KTBL, Darmstadt: FAL, Braunschweig.

## USING FISH RESPONSES TO ENVIRONMENTAL CONDITIONS

\*Halachmi I.

*Institute of Agricultural Engineering, Agricultural Research Organization, the Volcani Center, P.O. Box 6,  
Bet Dagan 50250, Israel*

*\* e-mail corresponding author: halachmi@volcani.agri.gov.il*

---

### INTRODUCTION AND OBJECTIVE

Fish growth rate was quantified as a function of measurable parameters. The objective of this research was to use this data to manipulate fish growth rate in order to match production with market demand.

### METHODS

The case study presented is based on:

(1) data from a re-circulating aquaculture system (RAS) at Kibbutz Hazorea, Israel, in which koi (*Cyprinus carpio*) are raised in fifteen plastic tanks of capacity 20m<sup>3</sup> each. This RAS was built in 2001, and the production data used in the model were obtained from January 2004 to April 2005.

(2) data from Kibbutz Sde Eliahu's RAS, in which Nile tilapia (*Oreochromis niloticus*) are raised in 20 concrete raceways. This RAS has been working for 12 years.

The impact of environment-related variables and managerial parameters on fish growth rate is presented in Table 1. Market demand is presented in Figure 1. It can be seen that more than one parameter in Table 1 should be altered in order to meet the market demand in Figure 1.

The RAS was modeled by the *process-orientation* simulation method, in which a process comprises the sequence of operations or activities through which the fish progress. This simulation model was based on a modular approach: the system was broken down into 20 modules whose interactions yield the RAS behavior as output.

In the aquaculture context, simulation avoids the difficulties of empirical experimentation with the RAS. Being flexible and free from unimportant details, the iterative nature of modeling allows the isolation of a single parameter, with validation by means of any of a number of procedures. The main measures of performance (simulation model responses) are: (1) total sales revenue; (2) standing biomass and feed load at each biofilter; (3) stocking density in each culture tank; (4) utilization of each culture tank, and (5) rejection rate.

### RESULTS

Simulation experiments facilitated the joint evaluation of fish biology, equipment, management practices, farm routine and layout; they can highlight potential design options before the system is built. For example, it was noticed that under the conditions of the specific farm investigated in this study:

1) If one additional reproduction (hatching) per year was added, the maximum (the peak point) biomass load handled by biofilter II would be reduced from 8 to 5 tonnes.

2) If two reproductions per year were added, the system could absorb an additional 1 million fingerlings per year and consequently increase sales by 60% while maintaining the same biomass load on biofilter II.

3) If one could reduce the rejection rate from 80% to 44%, sales derived from the same amount of fingerlings could be raised by a factor of 3 without exceeding the biofilter limits. The next practical step would be to question whether the cost of improving the rejection rate by 36% (through the use of superior genetic lines, nutrition, water quality, etc., would be less than the improvement in revenue that resulted from increasing the sales volume by a factor of 3.

4) If the final koi size were reduced from 50 to 25 cm, the number of fingerlings could be doubled (to 5 million) without increasing the existing low biomass load handled by biofilter II (max = 3 tonnes, average = 2 tonnes), so that production could be raised by a factor of 3.

5) Alternatively, purchasing larger fingerlings (4.5 g instead of 0.1 g) could cause the biomass load to exceed the filter limitation (14 tonnes instead of 7.4 tonnes)

**Table 1.** Cross correlation matrix: the impact of environment-related variables and managerial parameters on fish growth rate

	Y	X <sub>1</sub>	X <sub>2</sub>	X <sub>3</sub>	X <sub>4</sub>	X <sub>5</sub>	X <sub>6</sub>
Y	1	0.64	0.14	-0.60	-0.49	0.34	-0.43
X <sub>1</sub>	0.64	1	0.45	-0.60	0.14	0.27	-0.32
X <sub>2</sub>	0.14	0.45	1	-0.26	-0.33	0.39	-0.23
X <sub>3</sub>	-0.60	-0.60	-0.26	1	0.15	-	0.29
X <sub>4</sub>	-0.49	0.14	-0.33	0.15	1	-	0.30
X <sub>5</sub>	0.34	0.27	0.39	-0.47	-0.36	1	-0.42
X <sub>6</sub>	-0.43	-0.32	-0.23	0.29	0.30	-	1
						0.47	
						0.36	
							0.42

Variables: Y (g/day) = fish growth rate; X<sub>1</sub> = final fish body weight (g) at market; X<sub>2</sub> = initial fish body weight (g) when fingerlings enter RAS; X<sub>3</sub> = batch size, number of fingerings at entering the RAS; X<sub>4</sub> = number of days in RAS; X<sub>5</sub> = season index (spring, summer, autumn and winter); and X<sub>6</sub> = mortality rate.

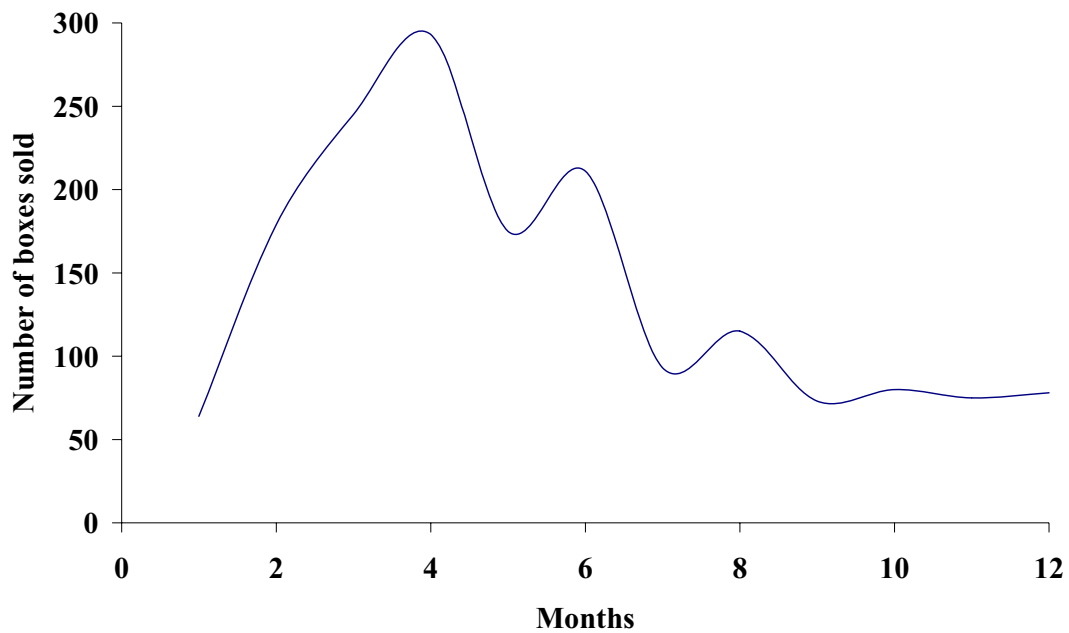

**Figure 1.** Market demand in terms of monthly sales of boxes during 2004. (The farm workers believe that if they had had more boxes ready between February and June, they would have sold more)

## CONTROLLING HEART RATE OF HORSES AS A BASIS FOR TRAINING IMPROVEMENT

Aerts J.-M., Gebruers F., Van Camp E., Berckmans D.

*Division Measure, Model & Manage Bioresponses, Katholieke Universiteit Leuven, Kasteelpark Arenberg 30, B-3001 Leuven, Belgium, e-mail: daniel.berckmans@biw.kuleuven.be.*

---

Few novelties have been introduced in equine training methods and consequently performance times have improved little since the last century. Nowadays it is possible to measure signals of biological systems 'on-line' by means of several new technologies and analytical procedures, and to process these signals immediately with powerful and compact processors.

The objective of this research was to explore the possibilities of using modern model-based algorithms to control the heart rate of horses (bpm) on-line by controlling input running speed (km/h).

Forty-five experiments with five horses and three riders were carried out in order to generate measurements of physiological status during running. Heart rate of the horses was measured with a Polar® S610i™ sensor, whereas running velocity was measured with a Garmin® Forerunner™ 201 GPS unit. From these data, dynamical characteristics of the different horses were quantified using linear discrete transfer function models. The dynamic response of heart rate to step-up and step-down in running speed could be described accurately by means of a transfer function model. In 90% of the cases, a first order model yielded the best fit. For 69% of the models, the  $r^2$  value was higher than 0.90 and for 34% of the models the  $r^2$  value was even higher than 0.95.

In a next step, cardiac responses of two horses (horse 2 and 4) were controlled to a pre-defined target level by making use of a model-based control algorithm. For the control algorithm, the best models for horses 2 and 4 were chosen from the step experiments. The model parameters were kept constant. An example of the target and actual heart rate trajectories is shown in figure 1. On average, the error between the defined target heart rate and the actual controlled heart rate ranged from 0.2 to 1.4 bpm for the entire heart rate trajectory. During the steady state part of the trajectory the average error was maximum at 1.1 bpm. When transitioning from one steady-state heart rate level to another, the average error could increase up to 5 bpm. A more detailed overview is given in Table 1.

In the future, combination of on-line measured bioresponses with real-time analysis will be used for adjusting the training workload of the horse to meet the immediate needs of the horse (welfare) and the trainer (performance).

Horse 2

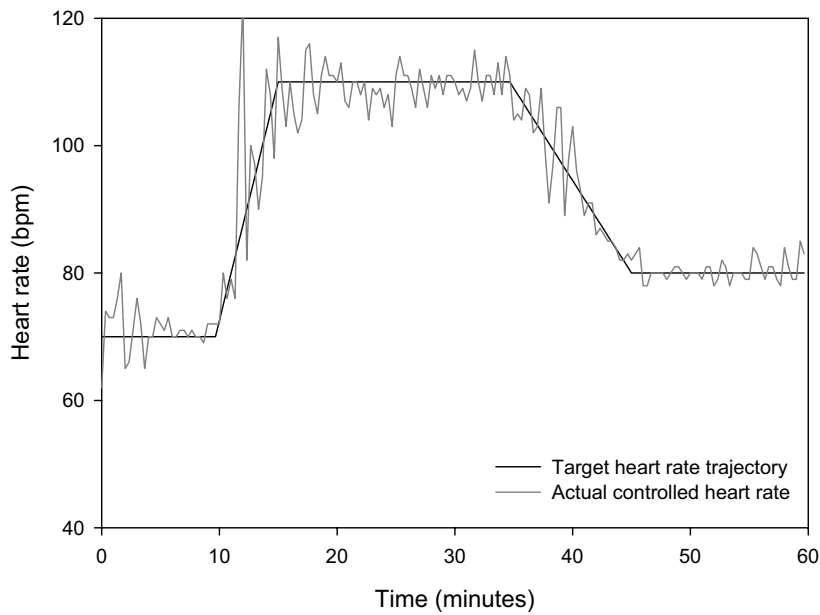

Figure 1. Example of heart rate control with reference to the target level for horse 2.

Table 1. Overview of the control errors of the heart rate controller for horses 2 and 4.

	Entire target trajectory		Steady state target trajectory		Transient target trajectory	
	Average (bpm)	SE (bpm)	Average (bpm)	SE (bpm)	Average (bpm)	SE (bpm)
Horse 2, trial 1	-1.8	7.3	-0.7	4.8	-5.0	11.6
Horse 2, trial 2	-0.3	4.6	-0.1	2.9	-1.0	7.6
Horse 2, trial 3	-1.4	6.6	-1.1	6.1	-2.2	7.8
Horse 4, trial 1	-0.6	4.2	-0.6	3.2	-0.8	6.3
Horse 4, trial 2	-0.2	3.3	0.0	2.2	-0.8	5.3
Horse 4, trial 3	-0.2	3.5	-0.3	2.5	0.4	5.4

## NITRIC OXIDE EMITTED FROM INCUBATED EGGS: CAN IT BE USED TO INDICATE EMBRYONIC STRESS?

Ar A.

Department of Zoology, Tel Aviv University, Tel Aviv, 69978, Israel. Email: amosa@tauex.tau.ac.il

### INTRODUCTION

Although methods to monitor and control the wellbeing of developing embryos in artificially incubated eggs do exist (e.g. temperature, ventilation and humidity controls; candling), there is still need for a more direct and effective non-invasive means to evaluate on line the development of stress conditions affecting the embryos that may arise in the incubator.

Nitric oxide (NO) is a short lived, reactive free radical gas, formed in tissues in minute quantities and is involved in a variety of biological processes, including blood flow regulation and angiogenesis (e.g.: Mathie and Griffith, 1999).

We consider the possibility of using the gas NO emitted from eggs as a stress signal (Samuni and Ar, 2006)

Recently, we identified the enzyme endothelial NO synthase in the chick chorioallantoic membrane (CAM), and have shown that NO gas escapes, or is emitted, from the egg through the shell (Ifergan and Ar, 1999; Reizis et al., 2002; Feldman and Ar, 2002; Ifergan et al., 2003; Amsalem et al., 2005).

#### Objectives

We speculate that the biologically produced NO takes part in regulating chorioallantoic (CAM) blood flow rate, and thus, in the absence of active ventilation, is involved in delivering oxygen to the embryo. We hypothesized that the magnitude of the emitted flux of NO is related to the physiological condition of the embryo.

### METHODS AND RESULTS

Experiments were conducted with incubated chicken eggs. Each egg was sealed in a chamber at a given temperature and constant O<sub>2</sub> concentration in its atmosphere. Carbon dioxide could be absorbed and water vapour was always absorbed. The chamber atmosphere was sampled at known times for NO levels, and O<sub>2</sub> was supplied from a reservoir to replenish and measure the consumed oxygen. Using this method, the rate of NO emission from the egg was calculated.

The method was used to establish a baseline of the normal pattern of NO emission from chicken eggs over the entire incubation period and to determine the rate of NO emission under different atmospheric conditions and temperatures.

Normal NO emission at the onset of the incubation was 184 picomol·hr<sup>-1</sup> (SE = 27; n=9), gradually decreased to 51 picomol·hr<sup>-1</sup> (SE=8; n=12) on days 7–8 and then increased again to 160 picomol·hr<sup>-1</sup> (SE=27; n=8) on days 19-20.

In response to hypoxia (14% O<sub>2</sub>), a significant increase in NO emission rate of about 20% above the control values occurs after 10 minutes on the 18<sup>th</sup>–19<sup>th</sup> day of incubation. Mild cooling (35.5°C), caused initially a small but distinct increase in NO emission and O<sub>2</sub> consumption rates followed by a decrease to about 75% of the control values in similar conditions on the same days.

NO emission rate from 16-day-old embryos, during 10 minutes progressive cooling towards a room temperature of 25°C, is significantly higher than in the steady-state control temperature (37.5°C). During the 1<sup>st</sup> to 2<sup>nd</sup> cooling minutes, NO emission increased to an average of ~38 times the control value. It declined after 8 to 10 minutes of cooling, to a value of ~6 times the control value.

Gradually increased CO<sub>2</sub> concentration to about 2%CO<sub>2</sub> (caused by absence of CO<sub>2</sub> absorption in the experimental chamber), caused NO emission rate of 16 day old embryos to reach a value of 145% over the control after 10 minutes.

Fluctuations of NO concentrations in commercial incubators are being tested. A need to control for environmental pollution of atmospheric NO has been detected.

### CONCLUSIONS

The differences in NO emission rates from eggs between control and experimental stress conditions suggest that detection of NO levels in incubators may serve as a sensitive and momentary indicator of embryonic stress. Such measurements should take into account embryonic ages, ventilation variation and intake of atmospheric NO. Results suggest that NO emission is linked to O<sub>2</sub> consumption, in particular during the incipient attempts of the embryo to thermo regulate and in the presence of high CO<sub>2</sub>.

## **REFERENCES**

1. Amsalem, E., A. Reizis, I. Hammel and A. Ar. Quantifications of NOS in different regions of the avian egg chorioallantois during incubation. *Isr. J. Zool.* 51: 58, 2005.
2. Feldman, A. and Ar, A. Nitric oxide mediates brood patch function in egg rewarming during incubation. The Zoological Society of Israel Annual Meeting, December 2002.
3. Ifergan O. and A. Ar. Embryo-incubating bird communication: yes or NO? *Isr. J. Zool.* 45: 309-310, 1999.
4. Ifergan O., A. Feldman and A. Ar. Involvement of the gas NO in embryonic thermoregulation during natural incubation. World's Poultry Science Association, Israel Branch. 40th Annual Convention, Ashkelon, Israel. March, 2003.
5. Mathie RT and Griffith TM (Eds.), *The haemodynamic effects on Nitric Oxide*. Imperial College Press, Lond., 518p, 1999.
6. Reizis A., Ar, A. and I. Hammel. Effects of gas composition and eggshell covering on the expression of nitric oxide synthase and the development of blood vessels in the chorioallantoic membrane of the avian embryo. *Proc. of The Zoological Society of Israel Annual Meeting*, December 2002.
7. Samuni and A. Ar. Can nitric oxide emitted from incubated eggs be used to indicate stress? *International Hatchery Practice*, 20, 4; p29, 2006.

*This work was supported by grant 422/01-05 of the Israel Science Foundation to A. Ar.*

## DEVELOPMENT OF THERMOREGULATION IN POULTRY EMBRYOS AND ITS INFLUENCE BY INCUBATION TEMPERATURE

Tzschentke B.

Humboldt-University of Berlin, Institute of Biology, WG Perinatal Adaptation, Invalidenstr. 43, 10115 Berlin, Germany, e-mail corresponding author: [barbara.tzschentke@rz.hu-berlin.de](mailto:barbara.tzschentke@rz.hu-berlin.de)

---

### INTRODUCTION

The early development of adaptive body functions in poultry, such as the thermoregulatory system, is characterized by the following peculiarities (Tzschentke et al., 2004): a) The development of peripheral as well as central nervous thermoregulatory mechanisms begins in the course of the prenatal ontogeny. b) Acute changes in the environmental conditions induce, as a rule, initially uncoordinated and immediate non-adaptive reactions. Later, the uncoordinated (immediate) non-adaptive reactions change into coordinated (adaptive) reactions. c) Functional systems of the organism develop from open loop systems without feedback control into closed systems controlled by feedback mechanisms. During this 'critical period', the actual environment modulates the development of the respective physiological control systems for the entire life period (Tzschentke and Plagemann, 2006).

### OBJECTIVES

The general purpose of this review is to show the stage of the development of peripheral and central nervous thermoregulatory mechanisms in poultry embryos at the end of incubation, and the impact of acute and long-term changes in incubation temperature (IT) on them.

#### Methods and results

Methods: Experiments were carried out with poultry embryos during the last third incubation period. Control eggs were incubated at an IT of 37.5°C. In the experimental groups the IT was 34.5°C and 38.5°C from the day of transfer to the hatcher to hatching. Heat production rate (HP) was calculated from O<sub>2</sub>-consumption rate, measured by indirect calorimetry. Embryonic temperature was recorded in the chorioallantoic fluid near the embryo. Respiration movements were detected using a Statham pressure transducer element, placed in the air chamber of the egg; and change in blood flow velocity was measured with a Laser-Doppler device. Activity of hypothalamic neurons was investigated in brain slices using extra cellular recordings. Neuronal c-fos expression was determined by immunohistochemistry. Thermoregulatory response of the respective mechanism was investigated during short-term temperature stimulation. The long-term effect of prenatal temperature was investigated during the first 10 days of post hatching on HP (same method as with bird embryos), and neuronal hypothalamic activity on body temperature (colonic temperature) as well as on temperature preference in a temperature gradient tunnel (10-45°C).

Results: (1) At the end of incubation, HP and heat loss mechanisms are developed in poultry embryos. In comparison with the heat loss mechanisms, the effectiveness of thermoregulatory HP is very low for bird embryos.

(2) Acute prenatal environmental stimulation may have a 'training effect' on the postnatal efficiency of the thermoregulatory system. These 'training effects' are necessary for the complete development of body functions like thermoregulation.

(3) In poultry, prenatal epigenetic temperature adaptation was developed by changes in the IT in comparison with controls: a low IT induced postnatal cold-adaptation and high IT induced postnatal heat-adaptation. Changes have been observed in the neuronal thermo sensitivity in the hypothalamus as well as in peripheral thermoregulatory mechanisms (Fig. 1). These alterations could be already found at the end of incubation (Loh et al., 2004).

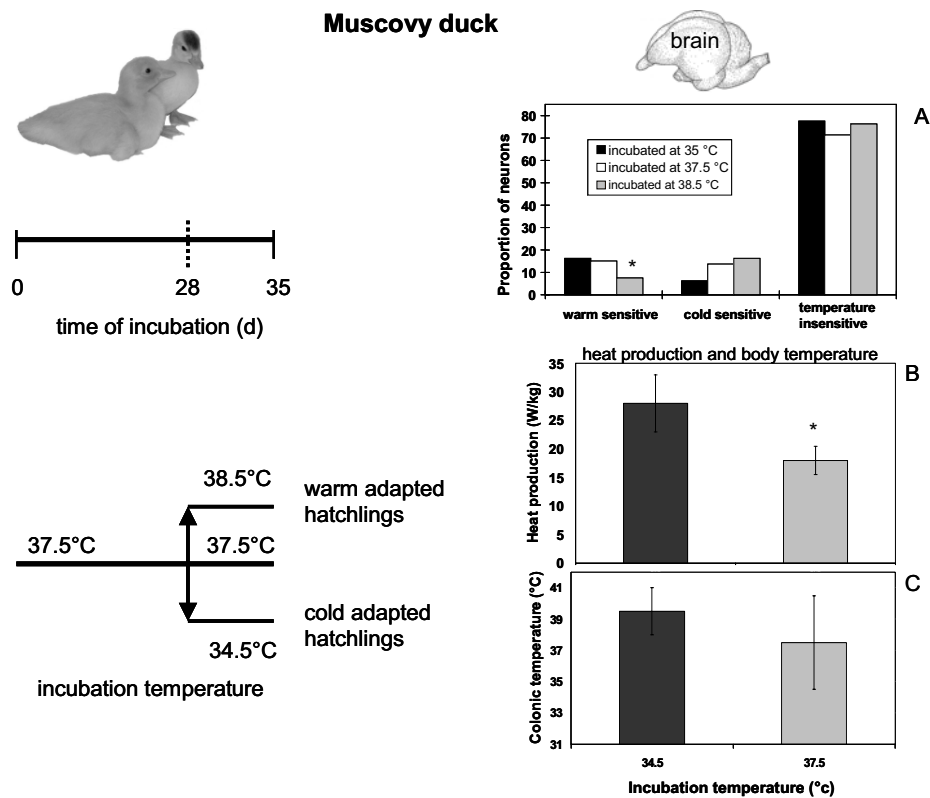

Figure 1: Epigenetic temperature adaptation in Muscovy duck embryos. Embryos were incubated from day 28 of incubation until hatching in either warmer or colder temperatures than the usual 37.5°C.

**A:** Changes in the neuronal hypothalamic thermo sensitivity at day 10 post-hatching induced by changes in the IT (significant differences,  $*p < 0.05$ ,  $\chi^2$ -test). For characterization of the neuronal hypothalamic thermo sensitivity the proportion of warm sensitive, cold sensitive and temperature insensitive neurons in the PO/AH was determined in relation to all neurons ( $n = 80$  neurons) investigated in the respective incubation groups.

**B:** HP and colonic temperature (**C**): C of hatchlings from cold (34.5°C) and normal (37.5°C) incubated eggs after 1 h exposure to 10°C (significant differences,  $*p < 0.05$ , t-test).

## CONCLUSIONS

At the end of incubation period, poultry embryos acquire all prerequisites needed to react to changes in IT. The development of the thermoregulatory system might be improved as a consequence of acute temperature stimulations. Knowledge on mechanisms of prenatal epigenetic temperature adaptation might be specifically used to generate long-term adaptation of the organism to the postnatal climatic conditions.

## REFERENCES

1. Loh, B., Maier, I., Winar, A., Janke, O., Tzschentke, B. 2004. Prenatal development of epigenetic adaptation processes in poultry: changes in metabolic and neuronal thermoregulatory mechanisms. *A&PBR* 15 (3/4), p. 119-128.
2. Tzschentke, B., Plagemann, A. 2006. Imprinting and critical periods in early development. *WPSJ*, in press.
3. Tzschentke, B., Basta, D., Janke, O., Maier, I. 2004. Characteristics of early development of body functions and epigenetic adaptation to the environment in poultry: focused on development of central nervous mechanisms. *A&PBR* 15 (3/4), p. 107-118.

# NON-DESTRUCTIVE ON-LINE MEASUREMENT OF ALBUMEN PH OF CHICKEN EMBRYOS AS A RESPONSE TO ATMOSPHERIC CO<sub>2</sub> CONCENTRATIONS

Van Brecht A. and Berckmans D.

*Division M3-BIORES: Measure, Model & Manage Bioresponses, Department of Biosystems (BIOSYST), Faculty of Bioscience Engineering, Catholic University of Leuven, Kasteelpark Arenberg 30, B-3001 Leuven, Belgium*

*\*e-mail corresponding author: daniel.berckmans@biw.kuleuven.be*

---

## INTRODUCTION

In the incubation process of domestic avian eggs (chicken, turkey, duck, etc.), the development of the embryo is mainly influenced by the physical micro-environment around the egg (Meir and Ar, 1987; Swann and Brake, 1990a,b,c). During the 21 days of embryonic development, the reaction of the embryo to its micro-environment evolves from purely biochemical to cybernetic when feedback interactions start to play a role between the organs and the micro-environment, which finally produces coordinated reactions as a result of the nervous system control. The level of the metabolism and the development of the embryo are a function of incubation time, incubation air temperature, gas conductance of the egg shell and atmospheric concentrations of oxygen (O<sub>2</sub>) and carbon dioxide (CO<sub>2</sub>) (Rahn et al., 1987). The yolk and albumen of a chicken embryo consists of 47.5% and 88.58% water, respectively (Burley and Vadhera, 1989). Since dissolved CO<sub>2</sub> dissociates in water to give bicarbonate and H<sup>+</sup> ions, the CO<sub>2</sub> concentration in the atmosphere around the egg will affect its pH. Carbon dioxide solubility and dissociation are also temperature dependent. Moreover, eggs tend to lose CO<sub>2</sub> during storage period. The pH level plays a key role in the activation of enzymes that are necessary for the development of the chicken embryo.

## OBJECTIVES

The objective of this research was to perform on-line measurement of temporal pH changes of albumen of chicken embryo and to investigate the influence of CO<sub>2</sub> levels in the micro-environment on it. We assume that the albumen pH may represent, at least in relative terms, the pH condition of the embryo.

## METHODS AND RESULTS

In three incubation experiments, three chicken eggs were incubated at 37.8°C in an atmosphere of variable CO<sub>2</sub> concentrations (Figure 1). During the incubation, CO<sub>2</sub> was added to control its concentration in the incubator. A Diamond mini pH electrode (response time < 20s, pH range from 1 to 14) was used for the on-line measurement of the albumen pH. It was introduced through a 2 mm diameter hole drilled in the eggshell and disinfected with ethanol. The sensor head at 2 mm diameter was immersed 2 mm in the albumen. The sensor was sealed with glycerol to the eggshell and was fixed to the egg tray. During normal incubation the albumen pH increased to a maximum of 8.9, 8.9 and 8.8 after 36h, 31h and 40h of incubation, for experiments 1, 2 and 3, respectively. Between 48h and 60h of incubation, the CO<sub>2</sub> levels used in experiments 1, 2 and 3 were 0.06%, 1.16% and 0.82% and the corresponding pH decreases were 0.40, 0.75 and 1.34 pH units per day. Although between 72h and 84h, the CO<sub>2</sub> concentrations in all experiments were brought to 1.4%, the pH decreases were 0.95, 0.27 and 0.26 pH units per day for experiments 1, 2 and 3, respectively. The largely different pH value for experiment 1 was related to the death of the embryo around 60h. On day 4, the CO<sub>2</sub> concentration in experiment 3 was reduced to 0.14%, changing the daily pH reduction from 0.26 to 1.02 per day. The increase in pH level of the embryo in experiment 2 on days 5-6 cannot be explained by the CO<sub>2</sub> concentration alone and might have attributed to the development of buffering mechanisms of the embryo.

## CONCLUSIONS

This research shows that the response of chicken embryo albumen during the first 7 days is not only determined by embryonic bio-chemical reactions, but mainly by the micro-environment. Moreover, the reaction is individual and time-variable. It is suggested that CO<sub>2</sub> concentrations may be used to control the pH level of the egg albumen, especially during day 1 to 4 of the incubation period, to alleviate the effect of CO<sub>2</sub> loss from egg storage.

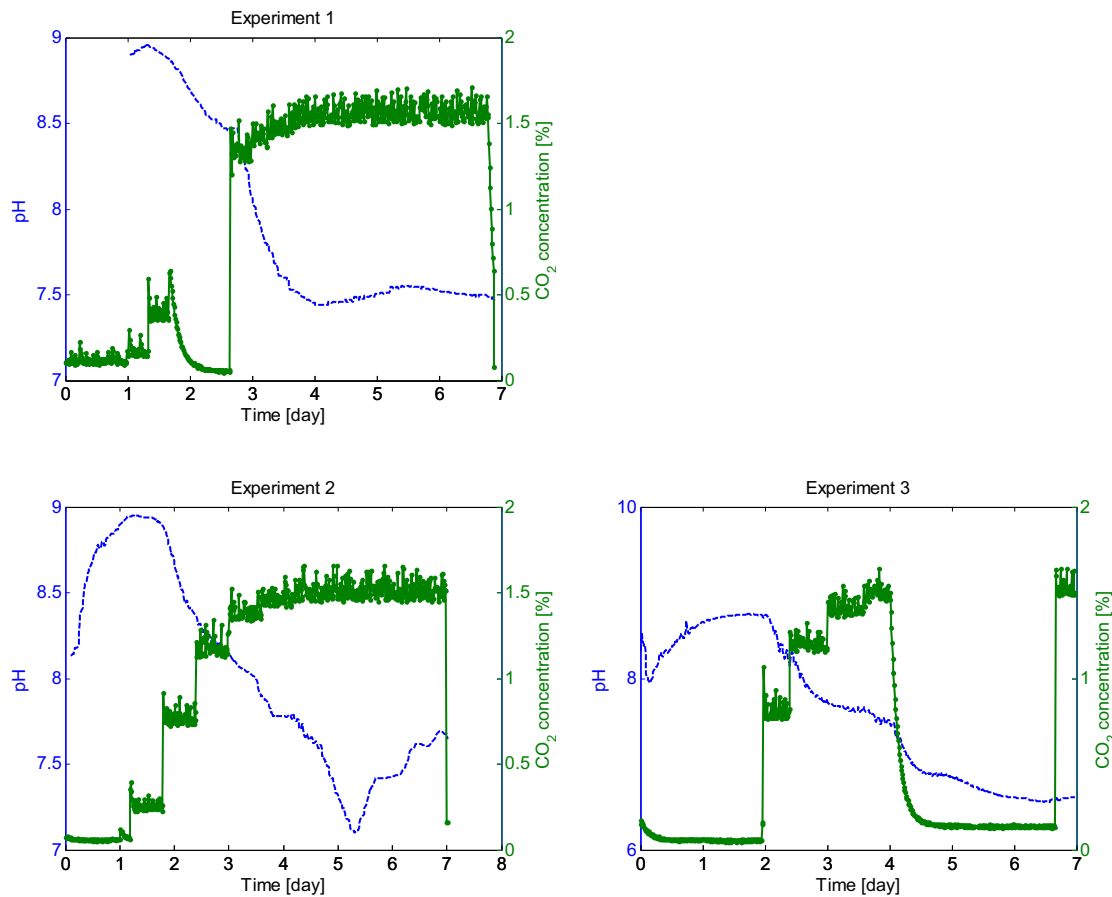

Figure 1. The CO<sub>2</sub> concentration in the incubator and the pH level of the albumen of the embryo during the first 7 days of incubation in experiments 1 to 3 (Please label the curves, i.e., pH and [CO<sub>2</sub>] – HX)

#### Acknowledgements

This research is the first result of a collaboration between the Division of Livestock-Nutrition-Quality and M3-BIORES. We kindly thank IWT<sup>1</sup> and Petersime<sup>2</sup> for funding this research.

#### REFERENCES

1. Burley, R.W. and Vadhera, D.V.; 1989. The avian egg, chemistry and biology. John Wiley and Sons, New York, Camacho, E. and Bordons, C.; 1999. Model predictive control, Springer-Verlag, London, pp. 280
2. Meir, M. and A. Ar. 1987. Improving Turkey Poultry Quality by Correcting Incubator Humidity to Match Eggshell Conductance. Br. Poultry Sci. 28:2:337-342.
3. Rahn, H., Paganelli, C.V., and Ar, A., 1987. Pores and Gas-Exchange of Avian Eggs - a Review. Journal of Experimental Zoology, p. 165-172
4. Swann, G.S. and J. Brake. 1990a. Effect of Dry-Bulb Temperature, Relative-Humidity, and Eggshell Conductance During the 1st 3 Days of Incubation on Egg Weight- Loss and Chick Weight. Poultry Science. 69:4:535-544.
5. Swann, G.S. and J. Brake. 1990b. Effect of Dry-Bulb Temperature, Relative-Humidity, and Eggshell Conductance During Days 17 to 21 of Incubation on Egg Weight- Loss and Chick Weight. Poultry Science. 69:4:545-553.
6. Swann, G.S. and J. Brake. 1990c. Effect of Incubation Dry-Bulb and Wet-Bulb Temperatures on Time of Hatch and Chick Weight at Hatch. Poultry Science. 69:6:887-897.

<sup>1</sup> Flemish Institute for the encouragement of the Scientific-Technological Research in the Industry

<sup>2</sup> Centrumstraat 125 - B-9870 Zulte – Belgium; <http://www.petersime.com>

## **EFFECTS OF DIFFERENT TARGET TRAJECTORIES ON BROILER PERFORMANCE IN GROWTH CONTROL**

Özlem Cangar, Jean-Marie Aerts, Erik Vranken and Daniel Berckmans

*Catholic University of Leuven, Faculty of Bioscience Engineering, Biosystems Department, Measure, Model & Manage Bioresponses: M3-BIORES, Kasteelpark Arenberg 30, B-3001 Heverlee / BELGIUM, Tel: (0032) 016321435, E-Mail: [ozlem.cangar@student.kuleuven.be](mailto:ozlem.cangar@student.kuleuven.be)*

---

### **INTRODUCTION**

Applying altered trajectories in broiler growth control with early feed restriction and a subsequent accelerated compensatory growth has been proved to result in better feed utilization efficiency and reduction in mortality. The properties of the growth trajectory and the resulting time and duration of the feed restriction can be crucial for the animal welfare and production performance. The objective of this work was to test different target trajectories for model based control in broiler growth.

### **EXPERIMENTS**

The experiments were performed simultaneously in two broiler houses. Each house had eight compartments and each compartment housed 1500 birds (Ross 308, mixed sex). With the eight compartments, each house contained 2 replicates of the control group featuring ad-libitum feeding and 2 replicates of three different restricted growth trajectories of 1) -10 %, 2) -15%, or 3) -20% of the standard ad-libitum feeding growth from day 22 to day 29. A model-based control algorithm was used to control the growth response of the broiler chickens to the input, feed intake, with the intention that it follows the predefined target growth trajectory. The dynamic response of the chicken was modelled using an on-line recursive estimation of the parameters.

### **RESULTS AND DISCUSSION**

To be able to follow the three target trajectories, birds were repetitively restricted until day 33. It was observed that the restrictions from day 10 to day 22 resulted in accelerated compensatory growth during the subsequent period of increased feed intake. Birds that were restricted until day 33 did not exhibit the same catch-up growth after put on ad-lib feeding.

Table 1. Results of the control algorithm for different growth trajectories: 1) -10 %, 2) -15%, and 3) -20% of the standard ad-libitum fed growth from day 22 to day 29, together with the control (ad-libitum fed) group. MRE stands for mean relative error in percentage between the reference trajectory and the measured weight.

	<b>Control (ad-lib)</b>	<b>-10% Growth <sup>1</sup></b>	<b>-15% Growth <sup>2</sup></b>	<b>-20% Growth <sup>3</sup></b>
MRE (%)	-	6.9	7.7	9.2
Maximum deviation (%) from the reference trajectory	-	20	21	23
End weight (g/bird)	2259	2072	1979	1982
Total cumulative feed consumption (kg/compartment)	6082	5557	5400	5226
Total mortality from day 10 to day 42 (number of animals)	35	28	35	48
Feed conversion as of day 42	1.77	1.75	1.78	1.74

Unachievable target trajectories caused the birds to be restricted for an extended time period. It was concluded that the broiler chickens had potential to exhibit a highly accelerated compensatory growth if restricted during the first 3 weeks of their growth period. Target trajectories which lead to restrictions after the 3<sup>rd</sup> week suppressed the growth and resulted in a considerably lower end weight. In controlling the growth of birds, the choice of the target growth trajectory is crucial. Hence a wrong choice can decrease animal health and production. These tests further demonstrated that the growth control algorithm should take into account the birds' health status besides feed and body weight.

## ALGORITHM FOR MEASUREMENT OF THE DAIRY COW'S BODY PARAMETERS BY USING IMAGE PROCESSING

<sup>1</sup>Hyeon T. Kim, <sup>1</sup>Han J. Ko, <sup>2</sup>Dae W. Lee, <sup>1</sup>T. Nishizu

<sup>1</sup>*Division of Environmental Science and Technology, Graduate School of Agriculture, Kyoto University, 606-8502, Kyoto, Japan*

<sup>2</sup>*Department of Bio-mechatronics, Sungkyunkwan University, 300, 440-746, Suwon, Korea  
e-mail corresponding author: bioani@kais.kyoto-u.ac.jp*

---

### INTRODUCTION

Recent mechatronics technology is the most appropriate high technology in agricultural applications to save repetitious labour. Cow's body parameters were measured by several traditional measurers. Image processing technology was used to measure automatically their parameters to reduce labour and time. The cow's parameter is in general used for breeding and improvement of cows in animal science fields. But the cow's body parameter is manually measured. Specifically, the cow's body parameter measurement is studied for weight prediction. Several researchers have developed methods of weight prediction of cows by the body parameters (Heinrich et al., 1987; McDaniel et al., 1965).

### OBJECTIVES

Research on dairy cattle was conducted by using image processing (Kim, 2001). But, those studies are focused on the identification for the precision livestock farming. Therefore, the research result regarding the measurement of cow's body parameters is used for the precision livestock farming. The body parameters based on auto detection will play an important improvement role for physical bio signal measurement of animals. Ultimately it will be possible to analyze bio physical signs from animals. We designed and developed the image processing system and image processing algorithms.

### METHODS AND RESULTS

This study was conducted to automatically measure the cow's body parameters, which are used for improvement of the cow in livestock production facilities. Measurement of her body parameters, which was executed by hand with the traditional measurer for her body parameters, used to take so much time and labour that a computer image processing technique came into use for easy and automatic measurement of the parameters.

The parameters were measured from a small model cow instead of a real cow. A real cow could not be easily measured because she does not stand still but moves around constantly while her parameters are being measured. The image processing system designed and constructed for this project was composed of a Pentium PC, a TV frame grabber card, and two digital-matrix cameras. The top camera views an area cm by cm at a distance of 30 cm from the bottom of system. And also the side camera views an area cm by cm at a distance of 25 cm from the centre line of system. The light source for image detection was the overhead fluorescent lamps with 200V and 60W mounted on the side and the top side of the cow.

### CONCLUSIONS

The body parameters of cow are an important element in selecting and breeding cows. However, the measurement of parameters requires much labour and time. We measured the cow's body parameters by using digital image processing with an image processing algorithm. Based on the results of this research the following conclusions were reached: The errors between the measured values of 9 parameters of the model cow and values calculated by the image processing algorithm were within 16.7%. They did not exceed the errors, which were generated by manual measurement.

The result showed that the measurement errors of the body parameters ranged from 1.1% to 16.7%. The Pin bone width of 16.7% is the largest measurement error in the nine body parameters measured, and the measurement error of the hip width is 14.5%.

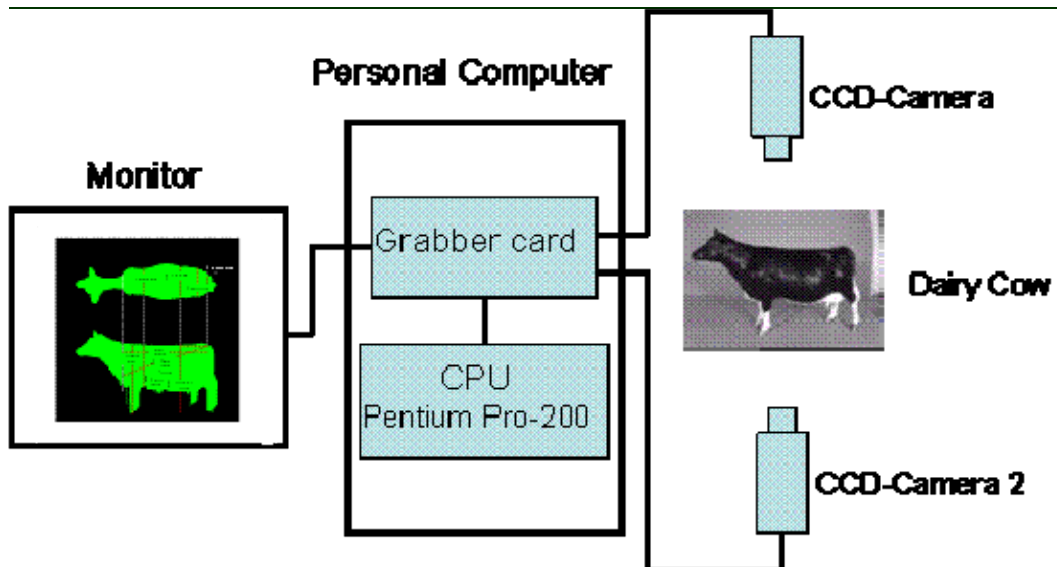

Figure 1. Block diagram of the image processing system

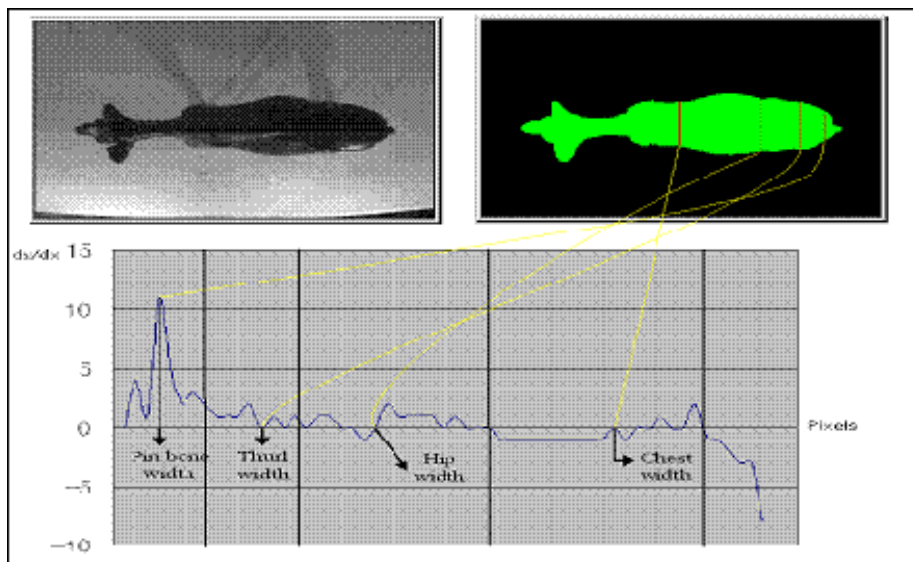

Figure 2. Intensity profiles taken from the prospective line in the top-view image

## REFERENCES

1. J. Heinrich and G. L. Hargrove. 1987. Standard of weight and Height for Holstein heifers. J. Dairy Sci. 70: 653-660.
2. T. McDaniel and J. E. Legates. 1965. Association between body weight Predicted from hert girth and production. J. Dairy Sci. 49: 947-956.
3. H. Kim (2001). Measurement of Body Parameters, Weight and An Individual Analysis with the Cows(Holstein) by Using Image Processing. Sungkyunkwan Univ. Doctoral thesis.

## UTILIZATION OF GPS HERD ACTIVITY AND WELFARE KIT (GPS HAWK) TO DETERMINE OPTIMUM SAMPLING PARAMETERS FOR INTENSIVELY MONITORING BEEF CATTLE

<sup>1</sup>Davis J.D., <sup>1</sup>Xin H, <sup>1</sup>Harmon J.D. and <sup>2</sup>Russell J.R.

<sup>1</sup>Department of Agricultural & Biosystems Engineering, Iowa State University, 3204 NSRIC Building, Ames, IA 50011, USA

<sup>2</sup>Department of Animal Science, Iowa State University, 337 Kildee Hall, Ames, IA 5001, USA.

---

### INTRODUCTION

Many researchers have utilized global positioning systems (GPS) in conjunction with geographical information systems (GIS) to study both wildlife and domestic animal behaviours. Most conventional GPS collars can be relatively expensive when monitoring multiple animals and have limited sampling capabilities for intensively monitoring livestock. To this end, researchers have had to extrapolate herd behaviour on data from only one or two animals out of a large herd.

### OBJECTIVES

The objectives of this study are to determine i) the effectiveness of using a subset of animals (randomly or specifically selected) to quantify whole-herd behaviour; ii) the minimum sampling interval required to determine specific behaviours of the animals, and, iii) to quantify environmental and geographical aspect effects on herd behaviour.

### METHODS AND RESULTS

A GPS Herd Activity and Welfare Kit (GPS HAWK) was developed by Davis *et al.*, (2005) as a low-cost platform to monitor individual livestock location along with up to six external sensor inputs. Fifteen autumn-calving cows, each fitted with a GPS HAWK, are being monitored in a 30-acre Bromegrass pasture under continuous grazing management at the Iowa State University Rhodes Research Farm. Water is provided by two water tanks and open access to Willow Creek. Water temperature of each water tank and the stream is monitored with a HOBO PRO external logger (Onset Computer Corp., Pocasset, MA). Environmental parameters (ambient temperature, relative humidity, solar radiation, wind speed and wind direction) are measured by a HOBO Weather station. Five other stations (Black-globe temperature, ambient temperature and relative humidity, wind speed and wind direction) traverse the creek valley to quantify differences in measured variables due to the change in terrain.

Each cow's location will be intensively sampled every 20 seconds over a two-week period each month from June until September 2006. This master data set of all 15 cows will be used to simulate the effectiveness of using a smaller subset to represent the herd. Secondly, the master set will be divided into larger sampling intervals (1 minute, 5 minute, 10 minute, etc.) to determine the effectiveness of each interval in monitoring grazing, travelling and lying behaviours. Finally, the effects of environmental and geographic aspect on herd behaviour will be reported.

### REFERENCES

Davis, J.D., Darr, M.J., Xin, H., Harmon, J.D. and Brown-Brandl, T.M. 2005. Development of a low-cost GPS herd activity and welfare kit (GPS HAWK) for livestock monitoring. Proceedings of the Seventh International Livestock Environment Symposium (18-20 May 2005, Beijing, China) eds. T. Brown-Brandl and R. Maghirang. , ASAE Pub #701P0205. pp. 607-612.



## AN AUTOMATED METHOD OF SIMPLE BEHAVIOUR CLASSIFICATION AS A TOOL FOR MANAGEMENT IMPROVEMENT IN EXTENSIVE SYSTEMS

Umstatter C., Waterhouse A. and Holland J.

Hill & Mountain Research Centre, SAC, Kirkton, Crianlarich, FK20 8RU, Scotland, UK  
e-mail corresponding author: [christina.umstatter@sac.ac.uk](mailto:christina.umstatter@sac.ac.uk)

---

### INTRODUCTION

The introduction of sensor guided management, even in extensive farming systems, is of increasing interest. For instance, hill farming in Scottish Highlands depends heavily on the changing types of subsidies and the wet climate, terrain and poor soils makes it very difficult to achieve high animal performance. Moreover, due to the climate, the working conditions are very harsh and high quality labour recruitment is not easy. With the CAP reform and the Single Farm Payment Scheme, the reduction of livestock numbers on the hills seems inevitable. These new changes in farming are very likely to have a high impact on environmental and rural issues, with yet unknown effects. In this situation it is important to develop new management options, which could make hill farming more profitable, particularly in making best use of limited labour. Therefore we ran a pilot study in Scotland, to gather behaviour information in two different grazing areas in autumn. The areas had different sward heights due to a different grazing management. To gather behaviour information we used GPS collars with integrated pitch and roll tilt sensors to collect data of the position of the sheep's head and neck.

### OBJECTIVES

The aim of the study was to find out if different behaviour types of sheep can be identified. The information can be used to identify behaviour changes e.g. due to animal welfare problems. This would provide a useful tool for comparing different systems or management options. Another aspect is to use this information to analyse GPS data regarding foraging behaviour of sheep to improve grazing management.

### METHODS AND RESULTS

We used 10 GPS tracker collars (200 series), developed by BlueSkyTelemetry, with integrated pitch and roll tilt sensors to gather behaviour and grazing information in late summer and beginning of autumn at two hill sites in Scotland. We collected 32 data sets for site 1 (Borders) with 6393 locations per sheep on average and a standard deviation of  $\pm 1204$  locations (range from 3334 to 7797). 26 analysable data sets were recorded for the site 2 (West Highlands). The number of locations per sheep on average is  $6602 \pm 1246$  locations (range from 2876 to 7807). At both sites we used two different areas with different sward heights.

Additionally, we have observed collar-wearing sheep inside a shed and outside in the fields. Each observation was recorded at a 30-second interval. In total, we have got 4173 ( $\approx 35$  h) observations, 2181 ( $\approx 18$  h) made outside in a field and 1992 ( $\approx 17$  h) inside the lambing shed.

Animal positions were collected every 30 seconds and over that 30-second period, the minimum and maximum pitch and the minimum and maximum roll tilt were recorded. The energy supply for the GPS limited recording time to approximately 2.5 days per trial. We ran four trials per site. The collars were evenly distributed amongst sheep grazing the different sward heights. In each area, up to five sheep were wearing a collar. Technical problems anticipated that not all 10 collars could be used per trial. During the measuring period the sheep were still integrated in their flock to achieve a consistent behaviour. The measuring period started at least one day after the collars were put on the sheep. After analysing the pitch tilt and the observational data it was shown that the behaviour of the sheep can be split in two simple behaviour types: active sheep: mainly grazing and some walking; and inactive sheep: mainly lying (resting, sleeping and ruminating) and standing motionless, observing environment.

The two different behaviour types can be easily identified in figure 1. The pitch tilt data show significant differences between active and inactive behaviour. The roll tilt data also reveals differences but this occurs at a smaller scale. It has to be investigated in future if the sensors are good enough for more detailed behaviour analysis.

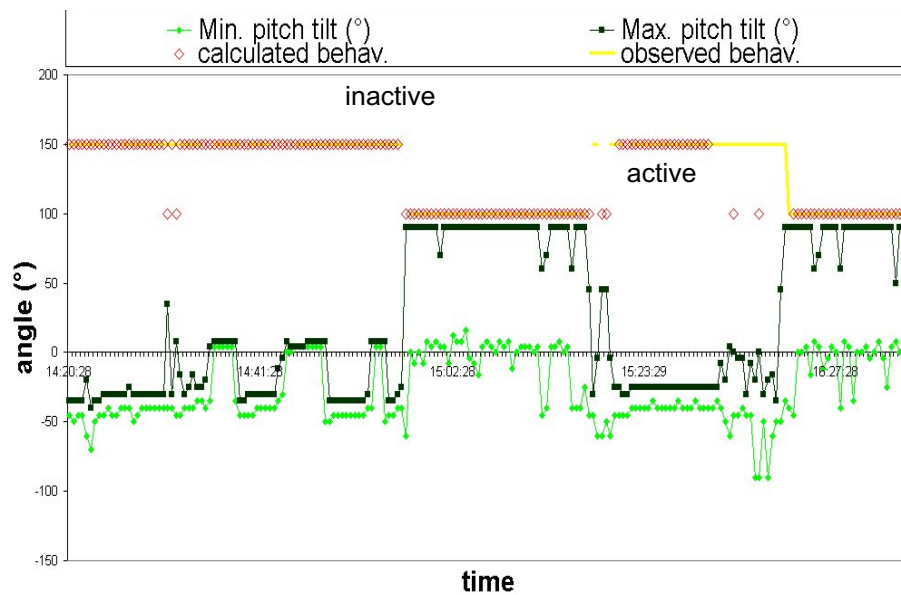

Fig. 1: Measured pitch tilts of a sheep's neck in comparison of classification by a decision tree and observed behaviour.

The data can be classified either by a decision tree or a discriminant analysis. Both options have got a proportion of correct identifications over 90%. The results have shown that the pitch tilt sensor on its own is sufficient enough to identify simple behaviour. But the use of a roll tilt sensor in combination with a pitch tilt sensor can improve reliability of the data. In our case it was a discontinuous experiment and we were able to check the sensors after each trial. On a commercial farm an increased redundancy can be important to provide reliable data and to install an alarm system, just in case a sensor fails to achieve the targets. The question of reliability and redundancy has to be discussed under the circumstances of risk of failure and what happens to the animal in that case and how much the additional sensors cost. The sensor data for the behaviour "lying on the side" seemed to be underestimated when the decision tree is used, for improving it further animal observations have to be carried out.

## CONCLUSIONS

It was shown that only by taking pitch tilt data into account two simple behaviour types can be classified. The algorithms of the decision tree were proved to be very robust. The discriminant analysis of the data showed similar results.

The pitch tilt data is adequate for our purposes and the roll tilt data can be used to improve reliability. In further development the roll tilt sensor shall be used to identify sleeping behaviour of sheep on the side. In a follow up pilot study we collected seven data sets during parturition this year and the data analysis will show if it is also feasible to detect parturition in ewes automatically.

## MEASUREMENT OF ANIMAL DATA AND THEIR IMPORTANCE FOR HERD MANAGEMENT ON DAIRY COW FARMS

U. Brehme<sup>\*1</sup>, R. Brunsch<sup>2</sup>

Institute of Agricultural Engineering Bornim (ATB), D-14469 Potsdam  
<sup>1</sup>ubrehme@atb-potsdam.de, <sup>2</sup>rbrunsch@atb-potsdam.de

### ABSTRACT

Past and current investigations in Germany and Italy with sensor-aided measurement systems in cattle have shown the following results:

1. Body temperature plays a decisive role in health and oestrus detection. In contrast to activity control systems, automatic body temperature monitoring is in a positive stage of development and testing.
2. Body core temperature provides more exact data than body temperature, because the data are measured continuously over a long time.
3. In general, increased activity is a very good indicator that heat is approaching.
4. Due to increased activity, 50 to 60 % of the cows in heat can surely be identified only with a pedometer. The error rate is approximately 40 to 50 %.
5. From a combination of body temperature and activity it is possible to identify 90 % of the cows in heat. The combination also helps to identify cows with a silent oestrus.
6. Mucus conductivity is an useless parameter for a measurement system, because too many factors influence the data.
7. Our data logger system works well, giving an excellent picture of oestrus climax for best time of insemination.
8. Problems of the system: The dimension of the logger, it's not an invasive measurement method.
9. With heart-rate measurements we can identify stressful situations in livestock and oestrus cycle of dairy cows.

*Keywords: Management, dairy cow, sensor-systems, animal data*

Table 1: Comparison between the level of body temperature and body core temperature from heifers in climate rooms

	Outside temperature °C			
	+5 °C	+15 °C	+25 °C	+30 °C
heifer 1 climate room				
- scutulum temperature (KT)	38.2 °C	38.4 °C	38.4 °C	38.4 °C
- body core temperature (KKT)	39.5 °C	39.6 °C	39.5 °C	39.7 °C
- difference: KKT - KT	1.3 °C	1.2 °C	1.1 °C	1.3 °C
heifer 2 climate room				
- scutulum temperature (KT)	38.3 °C	37.9 °C	38.2 °C	38.2 °C
- body core temperature (KKT)	39.6 °C	39.6 °C	39.6 °C	39.8 °C
- difference: KKT - KT	1.3 °C	1.7 °C	1.4 °C	1.6 °C
heifer 3 climate room				
- scutulum temperature (KT)	38.4 °C	38.3 °C	38.4 °C	38.5 °C
- body core temperature (KKT)	39.5 °C	39.7 °C	39.6 °C	39.7 °C
- difference: KKT - KT	1.1 °C	1.4 °C	1.2 °C	1.2 °C
Reference heifer/stable	temperature in stable 15 °C to 18.5 °C			
- scutulum temperature (KT)	38.5 °C	38.3 °C	39.8 °C <sup>*)</sup>	38.3 °C
- body core temperature (KKT)	39.7 °C	39.4 °C	41.3 °C <sup>*)</sup>	39.6 °C
- difference: KKT - KT	1.2 °C	1.1 °C	1.5 °C <sup>*)</sup>	1.3 °C

<sup>\*)</sup> illness of the heifer in 3<sup>rd</sup> period

Table 2: Comparison of mean value differences between vaginal measured body core temperature (data logger) and body temperature measured in scutulum (thermo implant) with difference steps of outside temperature in climate room - example heifer 2

outside temperature °C		+5	+15	+25	+30
outside temperature °C	body temperature - scutulum - °C	body core temperature - vagina - °C			
		+39.64	+39.49	+39.43	+39.60
+5	+38.03	1.616 <sup>***</sup>	1.464 <sup>***</sup>	1.401 <sup>***</sup>	1.576 <sup>***</sup>
+15	+37.83	1.808 <sup>***</sup>	1.656 <sup>***</sup>	1.593 <sup>***</sup>	1.767 <sup>***</sup>
+25	+38.03	1.611 <sup>***</sup>	1.459 <sup>***</sup>	1.396 <sup>***</sup>	1.571 <sup>***</sup>
+30	+38.45	1.191 <sup>***</sup>	1.039 <sup>***</sup>	0.976 <sup>***</sup>	1.151 <sup>***</sup>

Figure 1. Activity and body core temperature in oestrus period

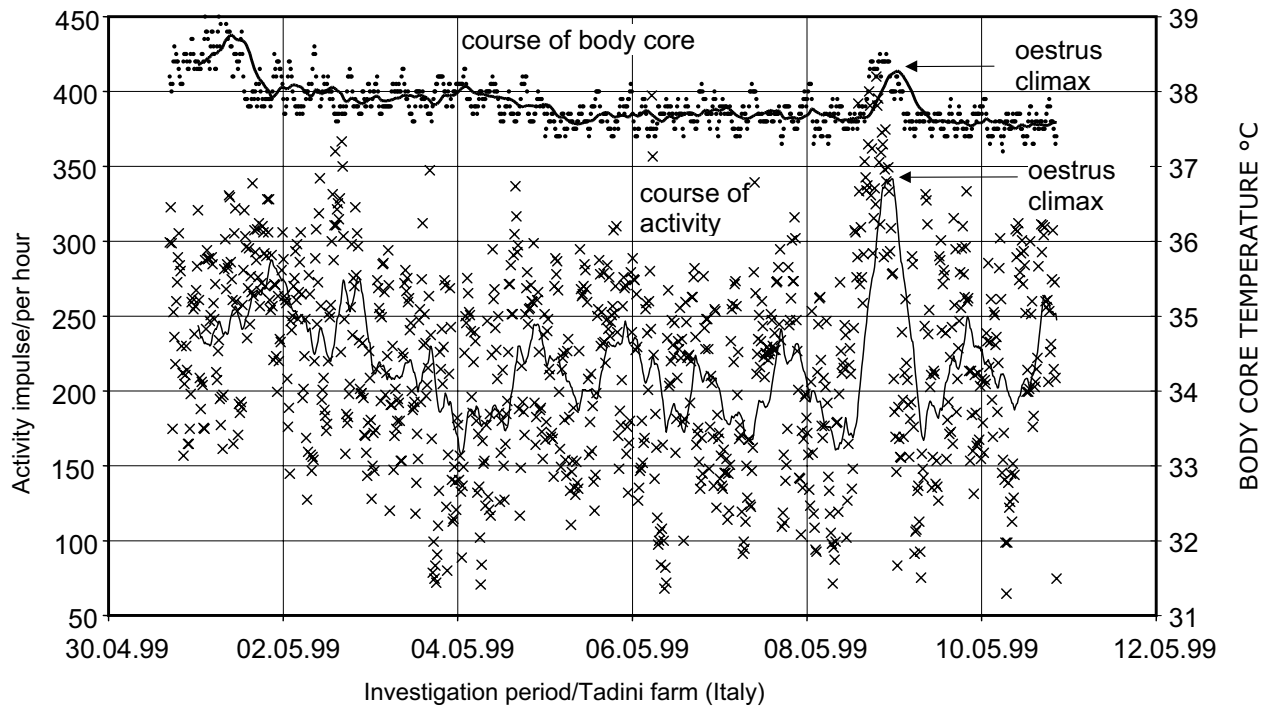

## LIST OF AUTHORS

Aerts J.-M.	p. 13, 43, 51
Ahlers D.	p. 27
Ahokas J.	p. 17, 25
Aisla A.-M.	p. 25
Antler A.	p. 9
Appel C.	p. 39
Ar A.	p. 45
Bak T.	p. 29
Berckmans D.	p. 13, 23, 31, 34, 43, 49, 51
Beuche H.	p. 27
Brehme U.	p. 27, 59
Brunsch R.	p. 59
Cangar O.	p. 31, 51
Costa A.	p. 13
Davis J.D.	p. 55
Demmers T.G.M.	p. 33, 36
Fallon R.	p. 31
Ferrari S.	p. 34
Fonss A.	p. 8
Gebreurs F.	p. 43
Goense D.	p. 11
Green A. R.	p. 33
Guarino M.	p. 13, 31, 34
Halachmi I.	p. 9, 41
Harmon J.D.	p. 55
Hartung E.	p. 39
Hasseler W.	p. 27
Hautala M.	p. 17, 25
Hogewerf P.	p. 11
Holland J.	p. 57
Houwers W.	p. 11
Ipema A.	p. 11
Jungbluth T.	p. 39
Kim H. T.	p. 53
Ko Han J.	p. 53
Lee D. W.	p. 53
Lenehan J.	p. 31
Leroy T.	p. 13, 23, 31
Lima K.A.O.	p. 15, 37
Lowe, J.	p. 7, 36
MacArthur-Clark J.	p. 33
Maltz E.	p. 9 19
Mc Gowan M.	p. 7
Mee J.	p. 31
Mendes A.S.	p. 37
Mentasti T.	p. 13
Mottram T.	p. 7
Moura D.J.	p. 15, 37
Munksgaard L.	p. 8
Naas I.A.	p. 15, 37
Nadimi E.S.	p. 29

Nishizu T.	p.	53	
Oliviero C.	p.	17	
Oudshoorn F. W.	p.	29	
Pastell M.	p.	17,	25
Peltoniemi	p.	17	
Philips N.	p.	7	
Poikalainen V.	p.	25	
Poppi D.	p.	7	
Praks J.	p.	25	
Roest van H.	p.	11	
Rusell J.R.	p.	55	
Schmilovithch Z.	p.	9	
Silva M.	p.	34	
Silva W.T.	p.	15,	37
Song X.	p.	23	
Stollberg U.	p.	27	
Tolon Y.B.	p.	15	
Tzschentke B.	p.	47	
Umstatter C.	p.	57	
Vainio O.	p.	17	
Van Brecht A.	p.	49	
Van Camp E.	p.	43	
Veermae I.	p.	25	
Vranken E.	p.	23,	51
Waterhouse A.	p.	57	
Wathes C.M.	p.	33,	36
Xin H.	p.	33,	55





PETERSIME



smart 2006

---